

# KÖNIGSWIESER

Die Seilwinde. Ein Leben lang!



## Operating manual

### KGD 85 SA

0115\_0003, 0115\_0004, 0115\_0016



# KÖNIGSWIESER

Die Seilwinde. Ein Leben lang!

# Table of contents

<b>1. Technical specification</b> .....	4
<b>2. Declaration of Conformity</b> .....	5
<b>3. Introduction</b> .....	6
<b>4. Safety Instructions</b> .....	7
<b>5. Mounting</b> .....	8
Mounting to the 3-point hitch .....	8
Assembly of the pto shaft .....	8
Shorten the drive shaft .....	8
<b>6. Operation Instructions</b> .....	9
Wire rope unwinding .....	9
Pulling .....	10
Release the wire rope under load .....	10
Emergency Stop .....	10
<b>7. Settings</b> .....	11
Installing a new rope .....	11
Coiling the wire rope tightly onto the drum .....	12
Setting the wire release power .....	12
Setting the winch brake power .....	13
<b>8. Maintenance</b> .....	14
Control of hydraulik oil .....	14
Lubrication .....	14
Checking and tightening the drive chain .....	15
<b>9. Removal of Faults</b> .....	16
<b>10. Spare parts catalogue</b> .....	18
<b>11. Warranty sheet</b> .....	30
<b>12. Notes</b> .....	31

## 1. Technical specification

### KGD 85 SA

<b>Pulling force below</b>	8.5 to
<b>Pulling force above</b>	3.7 to
<b>Wire rope medium speed</b>	0.6 m/s

#### Wire rope maximum length

Ø 12 mm	140 m
Ø 13 mm	120 m
Ø 14 mm	100 m

<b>Weight (without wire rope)</b>	675/695/719 kg
<b>Width</b>	1'800/ 2'000/2'200 mm
<b>Height with protective net</b>	2'300 mm
<b>Category of 3-point Mounting</b>	II + III
<b>Tractor required power</b>	from 60 kW

## 2. Declaration of Conformity

in accordance with Directive 2006/42/EC

We, the

Königswieser Gerätetechnik GmbH  
A - 4655 Vorchdorf  
Einsiedlingerstr. 51

declare under our sole responsibility that the product

### **Logging winches**

**35 EH, 35 SA, 42 SA, 42 EH, 45 EH, 45 SA,**

**55 EH, 55 SA, 65 EH, 65 SA, 85 EH, 85 SA, 105 EH, 105 SA**

to which this declaration refers, complies with the relevant health and safety requirements of Directive 2006/42/EC and the requirements of the relevant EC Directives.

The following standard(s) and / or technical specification(s) were used for the appropriate implementation of the safety and health requirements stated in the EC directives:

**EN ISO 19472:2006**

Vorchdorf, 08.05.2024

Königswieser Günter, CEO

## 3. Introduction

This manual describes the KGD winch and includes information and maintenance instructions for a safe and efficient machine operation.

Please, read the operation and service manual carefully even if you are an experienced winch user. The manuals include information required for an efficient and safe operation of the machine. Regular maintenance guarantees economical and correct machine operation.

The skidding winch is delivered test run and test loaded.

## 4. Safety Instructions

Do not use the winch, before you have read and understood the manual! The owner is responsible for the guidance of all persons, who have to deal with the device. Do not use or service the winch before the becoming acquainted with it.

1. Only skilled persons may use and service the winch.
2. The winch must always be checked before use and at least once a day the safety conditions and the possible faults must be checked.
3. Check the moving parts. They have to be fastened to their places and in good condition. All the protections and the limiters have to be in places.
4. The winch must not be used even partly, without the protection parts.
5. When winching to downhill, the winch must be pulled from the side through an extra snatchblock.
6. It is perilous to be in the area between a load connected to the cable and a winch.
7. Before using the winch get acquainted with the controllers of the winch, test the stopping functions of the winch and of the tractor and all the other functions. Each function has to be in perfect order.
8. Check that the winch is free of rubbish and other obstructions.
9. Check that all the outsiders are in a safe area, at a distance of at least 15 metres, from the running machine. Warning signs must be installed in the area of approaching roads .
10. The cable must not be touched during winching with the hands.
11. When the winch is used on slopes, the load must not be followed from below.
12. The maximum load must be adapted to respective conditions.
13. Check that the moving chains are carefully fastened. The cable must not be coupled directly to the load.
14. The safety factor must be 2.5 for cable type couplings and 2 for chain type couplings.
15. Inform all skidding winch users about the dangers and how they can be avoided.
16. The skidding winch may be operated only if it is attached to a tractor.
17. The winch has to be fastened to 3--point hitch of the tractor. Defective fastening may cause a dangerous situation.
18. Do not let children or incapable persons operate the winch.

## 5. Mounting

### Mounting to the 3-point hitch

The winch can be mounted to the 3-point linkage of any tractor. Power transmission is obtained through universal shaft from tractor.

### Assembly of the pto shaft

If the PTO shaft is too long it may get pressed when the three point hitch is lifted up. This may cause damage to the bearings of the winch or to the PTO of the tractor. The PTO shaft must not be too short in any position. The PTO length is suitable, if the pipes do not reach the bottom.

### PTO is optional equipment

1. Mount the winch to the 3-point hitch of the tractor.
2. Raise the winch high enough to get the PTO shaft of the tractor and the winch to a horizontal level.
3. If you have a shortened PTO shaft available, put one end into the drive shaft and check that the distance of the locking of the other end. Take into account the additional clearance of approx. 20 mm.
4. Fasten the other end of the PTO shaft in its place and also move the winch sideways at the same time securing that the axis does not base.

### Shorten the dirve shaft

#### Both PTO halves must be shortened by equal amounts.

- First cut the thicker cover to a correct lenght. Remember 20 mm cleanrance. Then cut away the same amount from the form pipe. Make a similar shortening to the second half of the PTO shaft. Remove the burr with the file.
- Connect the PTO shafts within each other. Make sure by moving eevator carefully up and down that the shortening of the axis is sufficient. Check that the axis have 20 mm latitude.

## 6. Operation Instructions

### Wire rope unwinding

When the winch is properly connected, we can begin with unwinding of the wire rope. On tractors without a socket with constant current of 12 V, we can connect a supply cable in the socket, which is usually made for connection of light equipment on the trailer. Because of this, we have to turn on the position lights. On the steering console, press the white button to release the brake. Hydraulic cylinder shifts to position 1. The switch will permanently release the brake.

When unwinding, we have to be careful not to unwind the wire rope completely or leave at least three winds on the drum. Due to safety reasons, the wire rope is installed on the drum so that if the logs start to slide without control, the rope must “pull” itself off the drum. If the rope was pulled out with excessive force, we can pull out the entire wire rope during pulling. In this case, replace it according to the procedure, foreseen for wire rope installation.

### Warning

Steel rope must be completely unwound before first use and wind it back on the generator drum under load. For instance, we can do this so that we attach the rope to a standing tree and pull the tractor with slight braking to the tree. This procedure must be done also before trying to tow, if we towed downhill beforehand or if the rope was wound loosely during towing.

### ATTENTION!

Loosely wound steel rope can be damaged (stuck, bent) at greater load, so that it is prohibited to use it again.

**Warranty does not apply for a steel rope, which is damaged in such manner.**



## Pulling

Turn the „Wire rope release“ switch towards left and push the black button on the control console, and the winch starts to pull. When the „Pull“ button is released, the pulling is interrupted. During the interruption, the brake band automatically switches on and prevents the load from sliding when the pulling is stopped.

It is useful to know that at the constant drive power, the pulling power depends on the length of the wire rope coiled to the drum. The strongest pulling power is achieved at the first layer of coils. By multilayer coiling the pulling power decreases progressively. The pulling power changes in inverse proportion to the pulling speed, which is highest when the wire rope is fully coiled.

### **Release the wire rope under load**

The brake prevents tied load from sliding back, when you stop the pull. To release the stretched wire rope, quickly push and release the white button repeatedly to prevent the drum from uncoiling suddenly and loosening the coiled wire rope. If the wire rope on the drum gets loose, the outer coils of the wire rope get under the inner coils at the repeated pulling, and the wire rope gets damaged quickly.

### **Emergency Stop**

By pushing the »Emergency Stop« button, the pulling and wire rope release functions are stopped. The button mechanically locks in the pushed position. In this position the pulling or wire rope release functions do not work. Turn the button slightly to the right to disengage the emergency stop. In case any function button is pushed when the emergency stop is disengaged, the machine will detect the malfunction and prevent the »pushed« button from operating.

## 7. Settings

### Installing a new rope

- Remove cover 1
- Bring the drum in position the reach screw 2 through the opening
- Unscrew the screw
- Insert the new rope from above
- Tighten the screw and close the cover
- Coil up the wire rope onto the drum tightly (see next Chapter!)

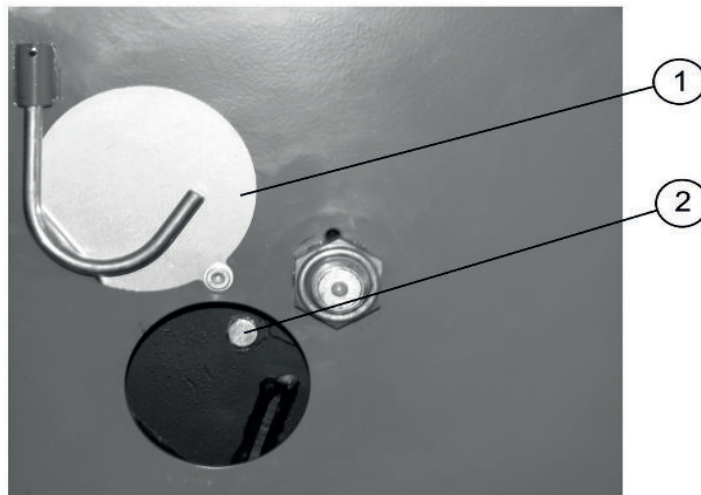

## Coiling the wire rope tightly onto the drum

First, uncoil the wire rope completely and check its quality. Afterwards push the “Pull” button to coil up the wire rope onto the drum. Pay attention to coil the first five coils using minimum force and the rest of the wire rope using higher force.

You can achieve this in two ways:

- By pulling the load;
- By fastening the wire rope to a fixed object, so that the tractor is pulled towards this object.

It is recommended to do this on a slight incline, so the tractor is pulled uphill, or by braking slightly

**WARNING:** The wire rope must always be tightly coiled up onto the drum – before starting the work with a new winch it is necessary to uncoil the wire rope completely without any load, check its quality and tightly coil it back onto the drum: first five coils should be coiled by using minimum load and the rest of the wire rope using higher load!

Setting the wire rope release power.

## Setting the wire release power

The wire rope release power must be set correctly, so the drum stops immediately after releasing the wire rope. This prevents the wire rope on the drum from releasing by itself. Set the wire rope release power using the wing nut. By screwing or unscrewing the wing nut, the wire rope release power increases or decreases.

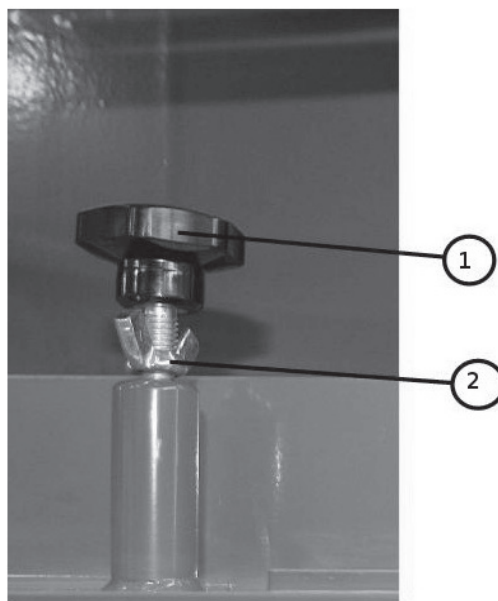

## Setting the winch brake power

At the end of pulling, the differential brake automatically engages. The brake is factory set, and a new setting is usually not required in the warranty period. After a longer period partial wear of the frictional padding on the brake belt occurs and it is required to set it again. This is required when the brake does not hold the burden as described in the beginning of this paragraph. Perform the setting by tightening the nuts (pos.1+2 ), which tightens the spring. Then, control the distance between the nut (pos. 2) and cylinder on a lever (pos. 3). This distance should be 5 mm, when the brake is not loaded. If the brake is properly set, is determined when unwinding the wire rope from the drum, which must unwind easily. This unwinding depends on previously set pre-brake, which is described in the previous chapter.

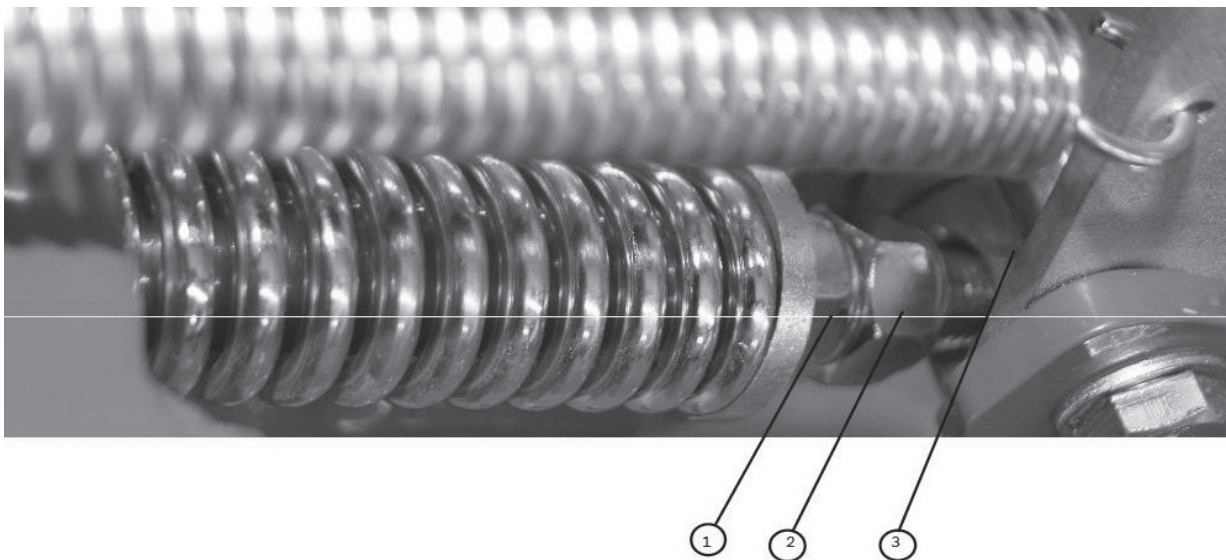

## 8. Maintenance

### Control of hydraulik oil

Oil level in the tank needs to be controlled occasionally. Oil level in the tank is 3.5 liters. For hydraulic system, oil for hydraulic systems ISO 32 is used. In summer months, when the ambient temperature surpasses 25 °C, oil ISO 46 needs to be used. First oil change needs to be done after 1000 hours of operation. Each next oil change must occur after 1000 hours of operation or at least once a year. During operation, oil temperature needs to be controlled. If this surpasses 70 °C, the cardan must be stopped and the reason of overheating must be determined. If you do not have a thermometer present, you can check the oil temperature by touching the hydraulic line. This can be done only with the engine stopped. Otherwise, the hydraulic system can malfunction.

### Lubrication

Before proceeding with maintenance work, shut down the engine, remove the key and wait for all moving parts to stop.

There is a grease fitting on the winch, which enables greasing of the upper pulley and guide. The second grease fitting is on the housing of the lower pulley. Greasing is required every 60 hours of operation. The PTO shaft needs to be lubricated according to instructions of the manufacturer.

**Non-frequent greasing can cause wear of slide elements and consequentially a defect, which is not subject to warranty terms!**

Drive chain must be lubricated every 200 hours of operation. Lubricate it with spray for lubrication of chains or special grease, which does not melt at high temperatures, because the grease can come into contact with friction coating of the clutch.

First, remove the PTO shaft protection. Clean the chain before lubrication. Do not lubricate the part, where the grease can reach clutch with application.

**If grease comes into contact with friction coating of the clutch due do improper and excessive lubrication, this would mean a drastic reduction in pulling force and consequentially it would be required to replace the blades of the clutch, which cannot be a subject of this warranty!**

All other bearings on the winch are of closed type, therefore greasing is not necessary.

## Checking and tightening the drive chain

- Open screws (4) from the back side. Try not to open too much so the nuts dont fall off.
- Tighten nut (6) until chain (3) is tight.
- Tighten screws (4)
- Check chain – you should be able to move it 4-6mm

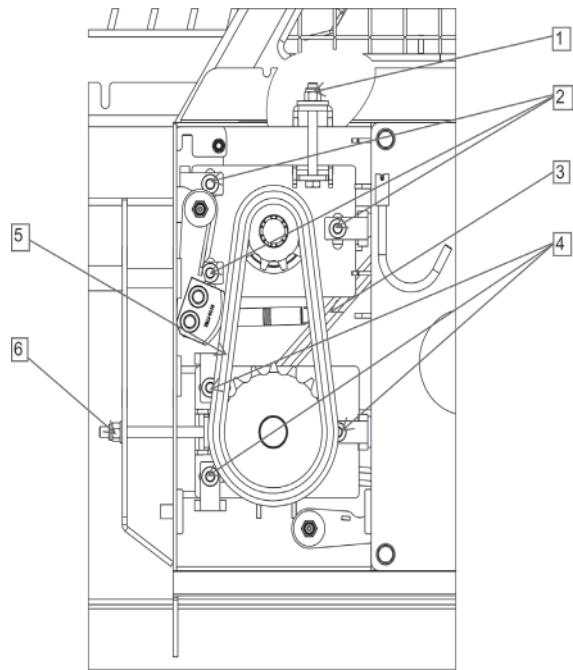

- now open screws (2)
- Tighten nut (1) until chain (5) is tight
- Check the small chain (7). if its too tight open screws(8) and adjust the height of the block.
- Tighten screws(2)
- check chain – you should be able to move it 4-6mm

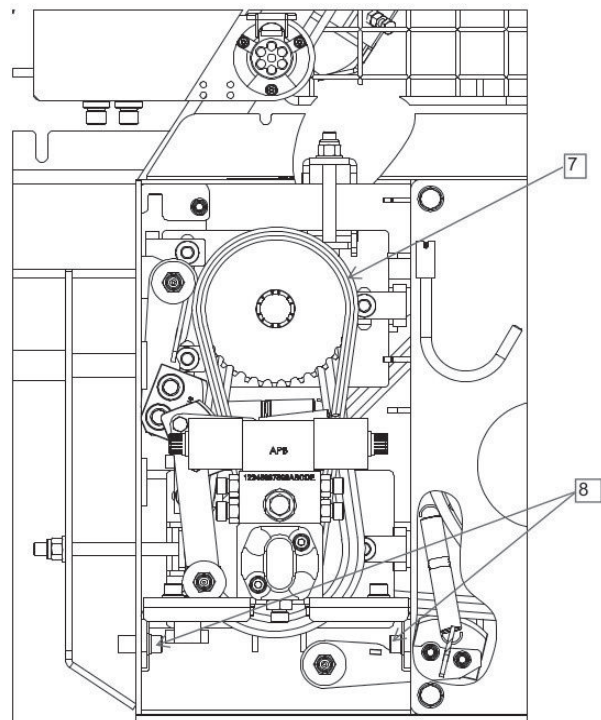

When finished check all chains again. You must be able to move every chain 4- 6mm.

## 9. Removal of Faults

Determined faults (malfunctions)	Cause	Procedure for removal of faults (trouble)
<b>Manometer does not show pressure</b>	Manometer does not work	Replace the manometer
	Sprocket does not drive the pump (broken axle, broken chains, spring pin on the sprocket)	Replace the damaged part
	Impurities in pressure valve	Unscrew the valve, clean it and replace it
	Folded tube	Replace the tube
	Not enough oil in the tank	Fill up oil in the tank
	Pump malfunction	Replace the pump
<b>Pressure drops too quickly</b>	The battery's membrane is damaged or nitrogen level in the battery is incorrect	Fill up nitrogen or replace the battery
	Impurities in steering valve	Unscrew the valve, clean it and replace it
	Non-return valve does not seal (impurities or malfunction)	Unscrew the valve, clean it and replace it.
	Pressure valve does not seal (impurities or malfunction)	Unscrew the valve, clean it and replace it or change it
<b>Clutch cannot be engaged</b>	Impurities in steering valve	Unscrew the valve, clean it and replace it
	No voltage / electrical current on the electro-magnetic coil	Check the electrical wiring and contacts
	Insufficient voltage on the electro-magnetic valve (min 11.6 V)	Check the electrical installation on the tractor
	Electro-magnetic coil does not work	Change the electromagnetic coil
<b>Brake cannot be engaged</b>	Impurities in steering valve	Change the electromagnetic coil
	No voltage / electrical current on the electro-magnetic coil.	Check the electrical wiring and contacts.
	Insufficient voltage on the electro-magnetic valve (min 11.6 V)	Check the electrical installation on the tractor
	Electro-magnetic coil does not work	Change the electro-magnetic coil

<b>Determined faults (malfunctions)</b>	<b>Cause</b>	<b>Procedure for removal of faults (trouble)</b>
<b>Pressure oscillates</b>	With each engagement of electromagnetic valve it is normal for the pressure to oscillate. If the pressure oscillates, when the valves are not engaging, this means that the pressure valve is damaged or there are impurities in the valve	Change or clean the pressure valve
<b>Insufficient pulling force</b>	Grease on frictional padding of the clutch	Replace clutches
	Burnt frictional padding of the clutch	Clean padding with sandpaper or grind (thickness approximately 0.5 mm)
	Insufficient pressure in hydraulic system (required pressure at least 140 bar)	Determine the reason for pressure drop
	Worn frictional padding of the clutch	Replace clutches
	Incorrectly installed clutch	Install according to technical documentation
<b>Insufficient brake force</b>	Improper setting	Setting according to instructions for use
	Grease on the padding og the brake belt	Replace the brake belt
	Damaged brake belt	Replace the brake belt
	Damaged brake mechanism	Replace damaged parts
<b>Wire rope cannot be pulled out or the pulling is difficult</b>	Improper setting of pre-brake	Setting according to instructions
	Improper setting of brake	Setting according to instructions
	Damaged or stuck wire rope	Pull out the rope with a tractor and, if required, install a new wire rope
	Damaged brake belt	Replace the brake belt
<b>The winch pulls, despite the clutch being disengaged</b>	Error on electro-magnetiv valve	Cease work immediately and consult a service company
	Not enough clutch distance	Setting according to instructions
	Broken part of frictional padding on the clutch	Replace clutches
	Excessively tensioned drive chain	Chain setting according to instructions
	Damaged winch drum	Replacement or repair of the drum

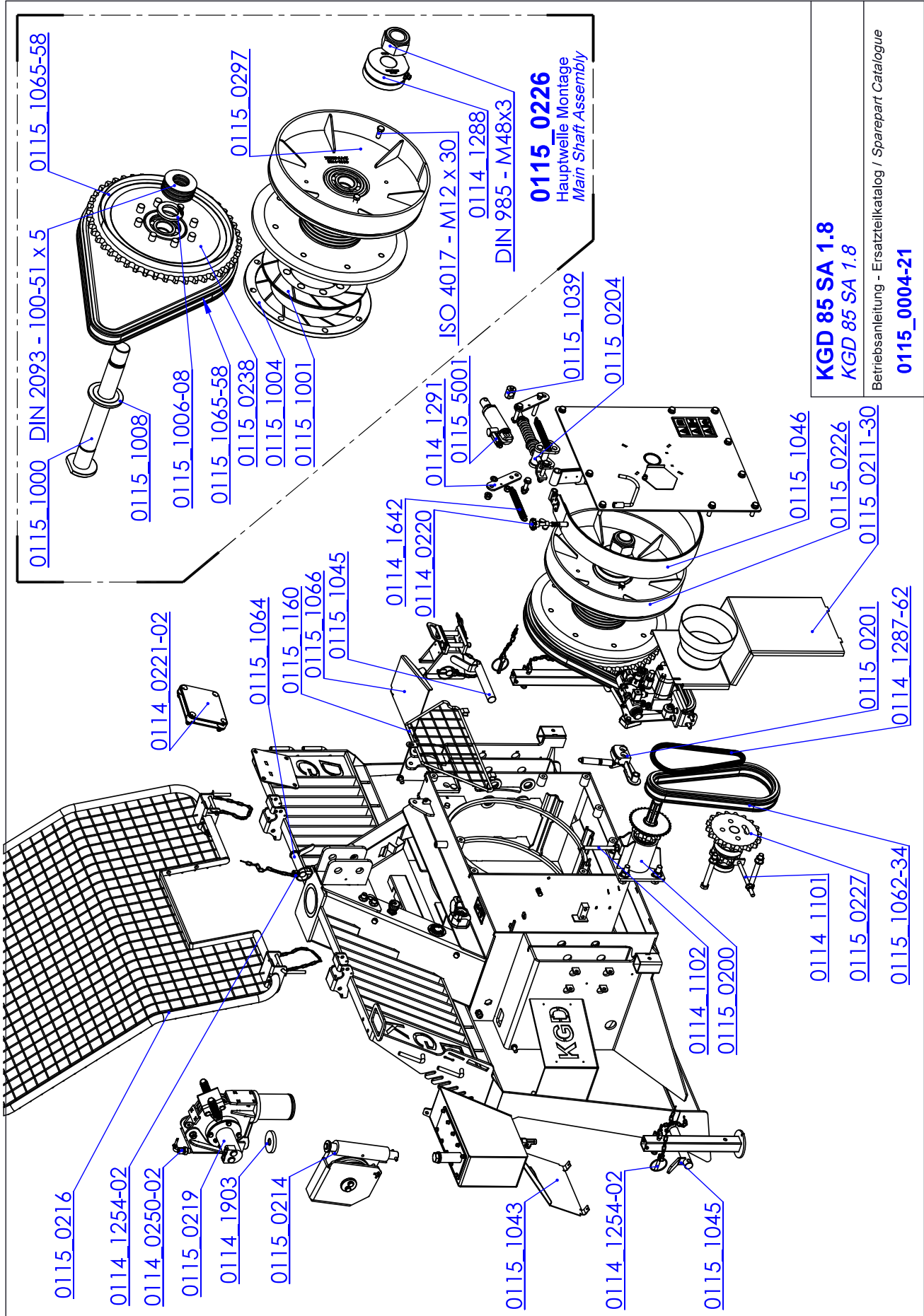

**KGD 85 SA 1.8**  
**KGD 85 SA 1.8**

Betriebsanleitung - Ersatzteilkatalog / Sparepart Catalogue  
**0115\_0004-21**

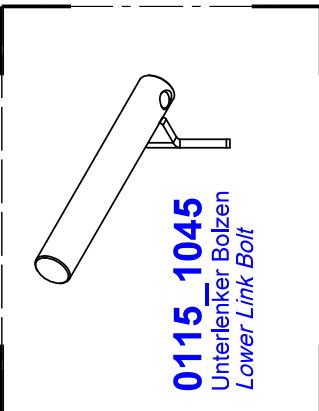

**0115\_1045**  
Unterlenker Bolzen  
Lower Link Bolt



**0115\_1064**  
Oberlenkerbolzen  
Upper Link Bolt

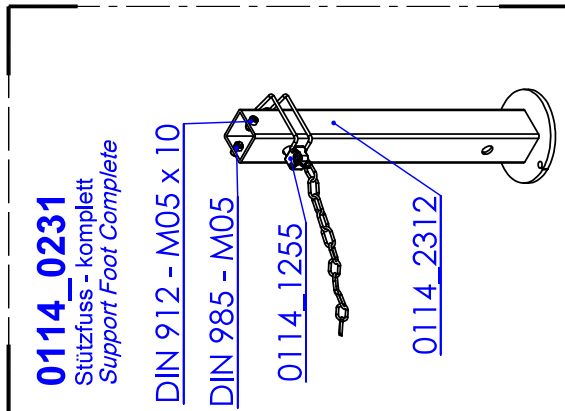

**0114\_0231**  
Stützfuß - komplett  
Support Foot Complete

DIN 912 - M05 x 10

DIN 985 - M05

0114\_1255

0114\_2312

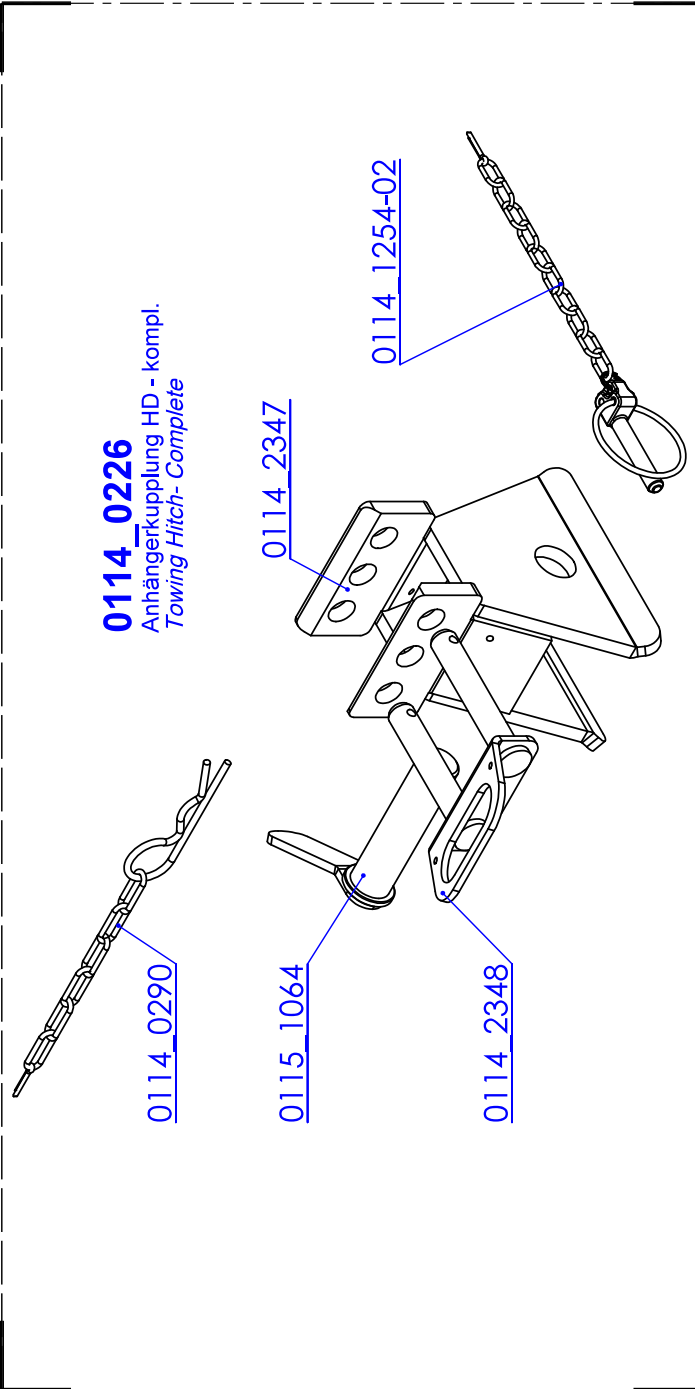

**0114\_0226**  
Anhängerkupplung HD - kompl.  
Towing Hitch- Complete

0114\_0290

0115\_1064

0114\_2347

0114\_1254-02

0114\_2348

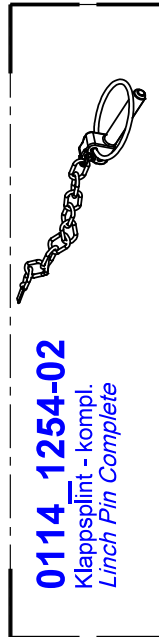

**0114\_1254-02**  
Klappsplint - kompl.  
Linch Pin Complete

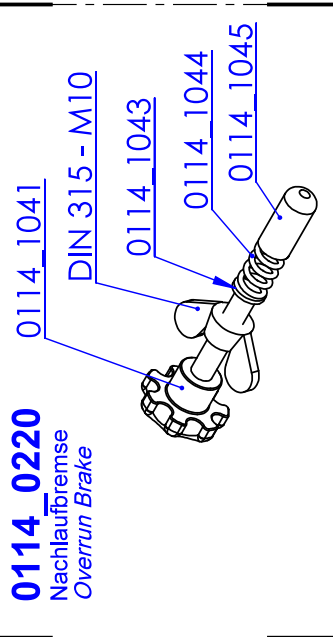

**0114\_0220**  
Nachlaufbremse  
Overrun Brake

0114\_1041

DIN 315 - M10

0114\_1043

0114\_1044

0114\_1045

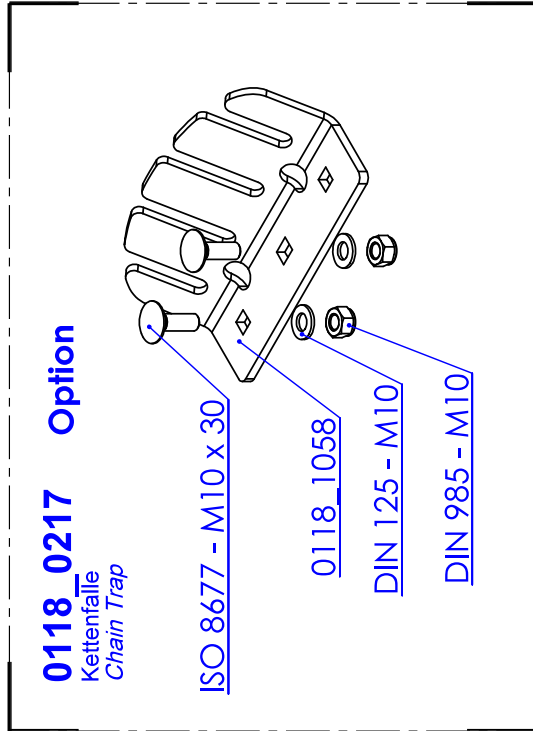

**0118\_0217** Option  
Kettensperre  
Chain Trap

ISO 8677 - M10 x 30

0118\_1058

DIN 125 - M10

DIN 985 - M10

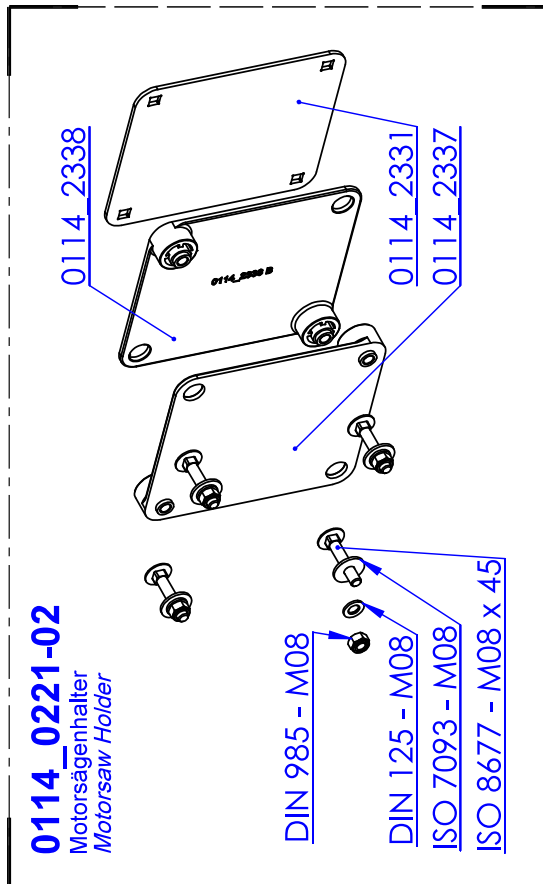
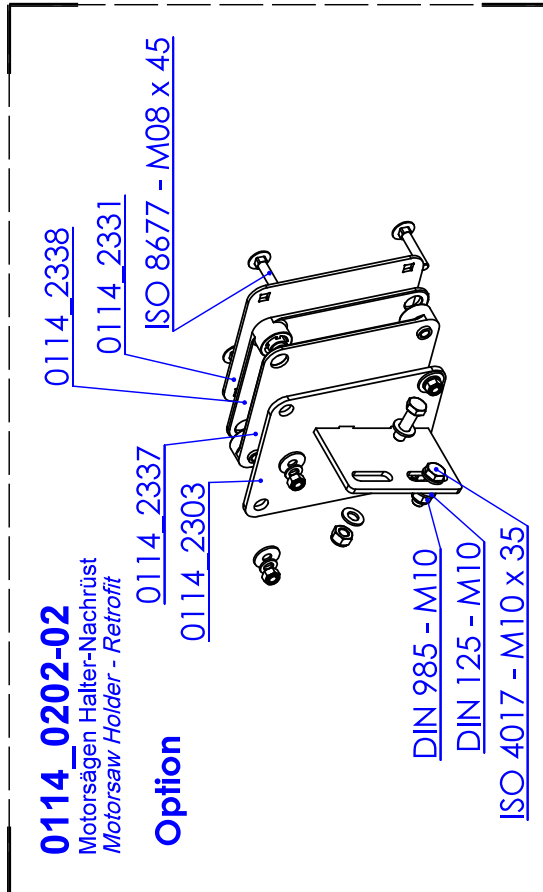
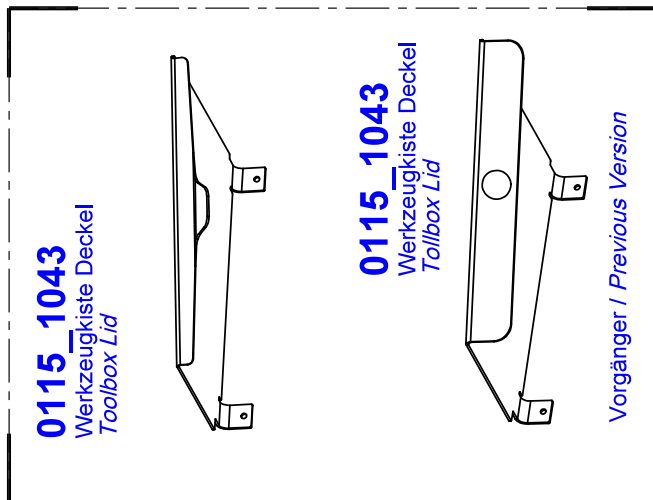
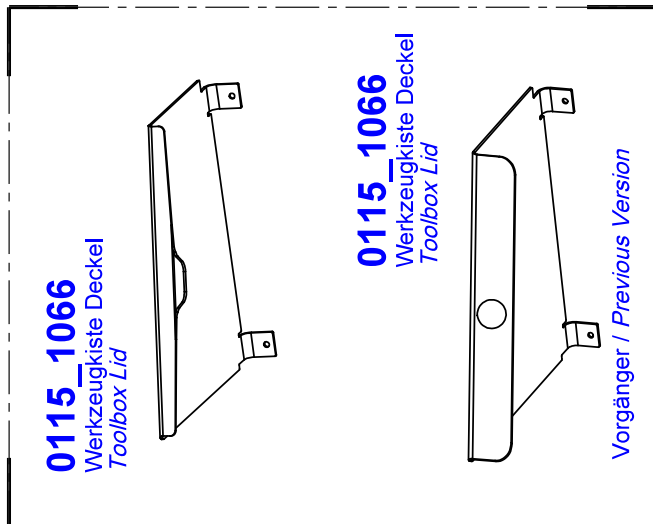
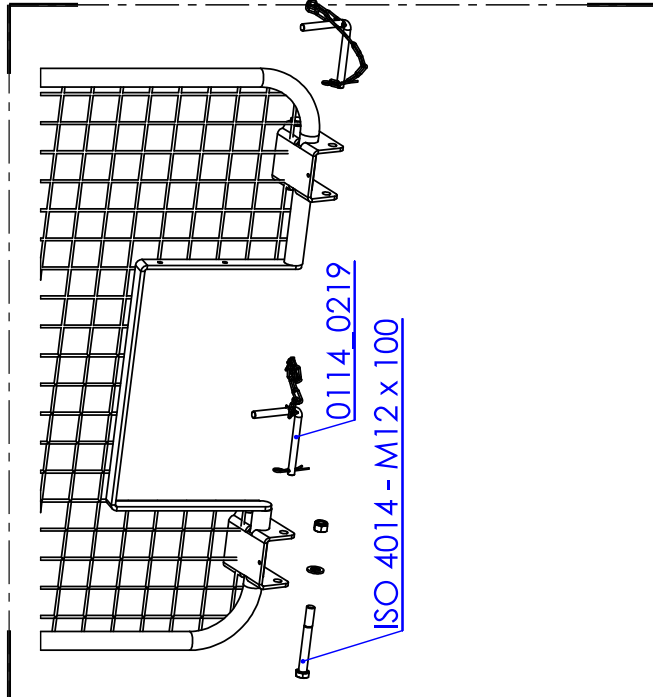



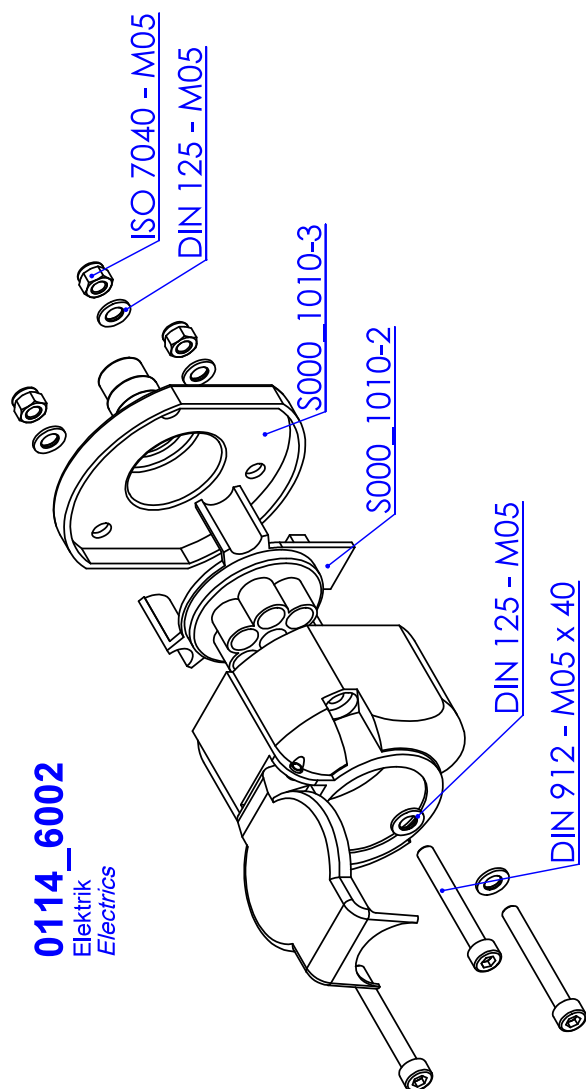

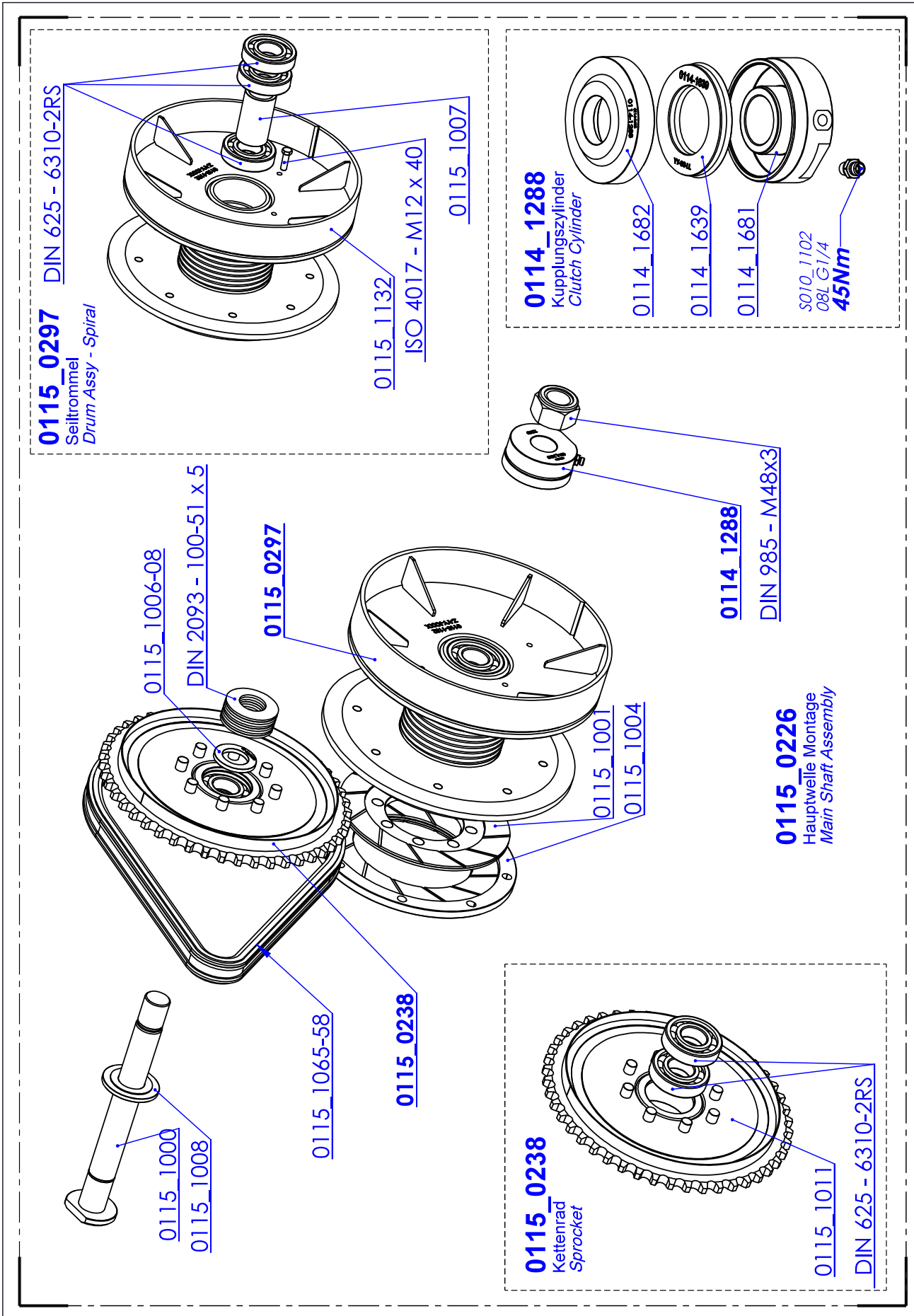

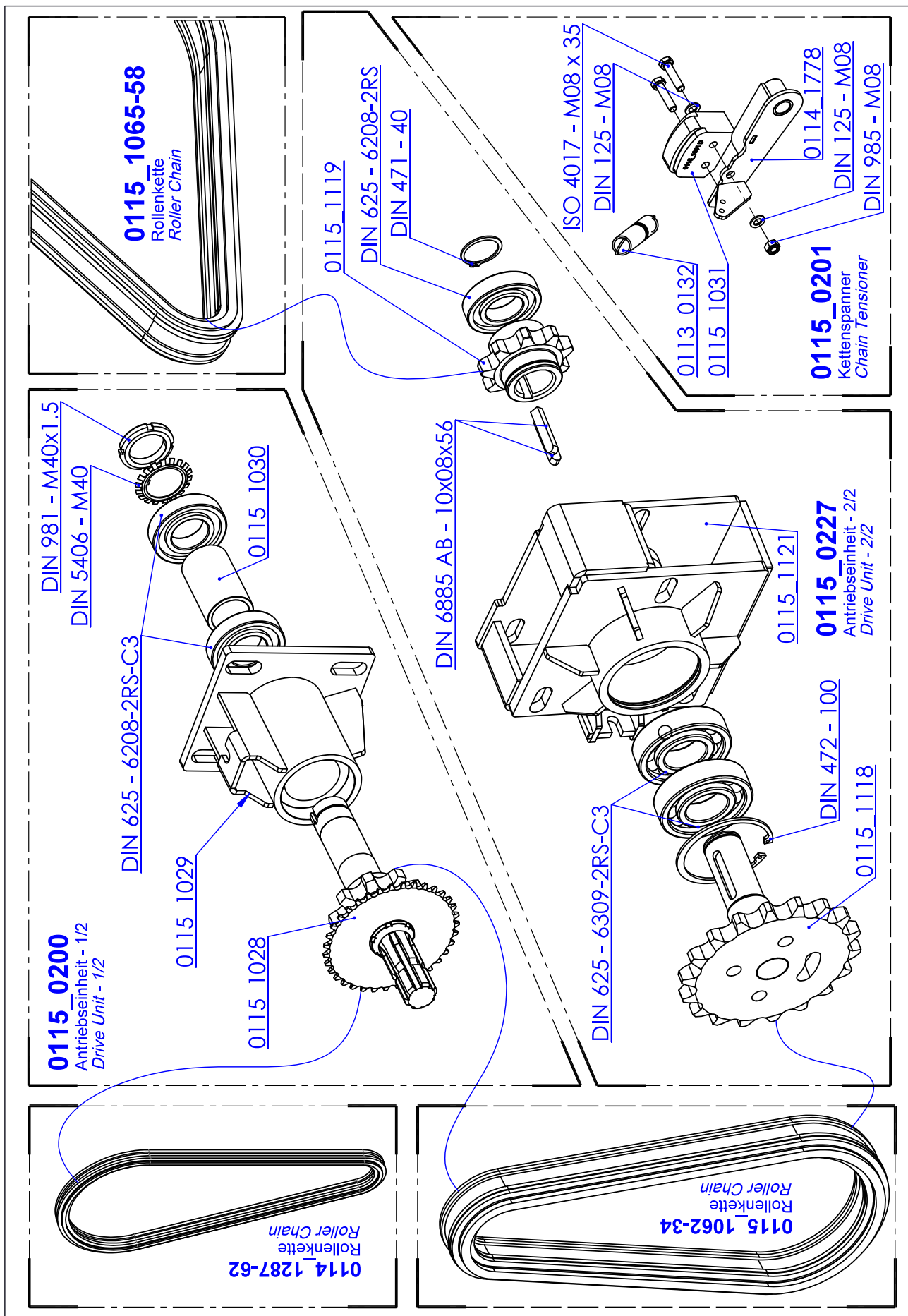

**0114\_5100**  
Manometer 06L  
Pressure Gauge 06L

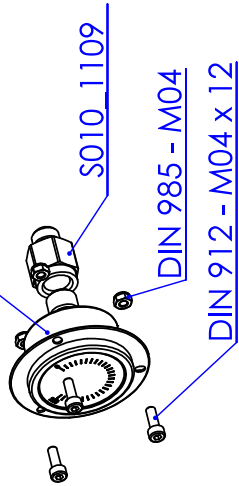

**0115\_5001**  
Bremszylinder komplett  
Brakecylinder complete

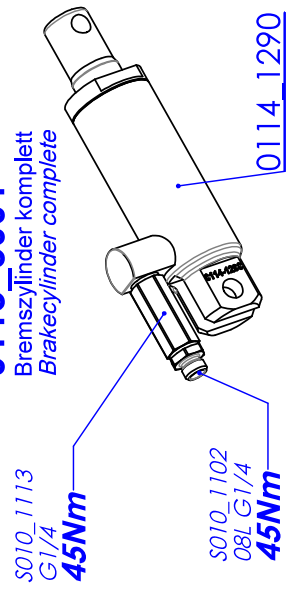

**0114\_5101-02**  
Druckspeicher kompl.  
Pressure Accumulator

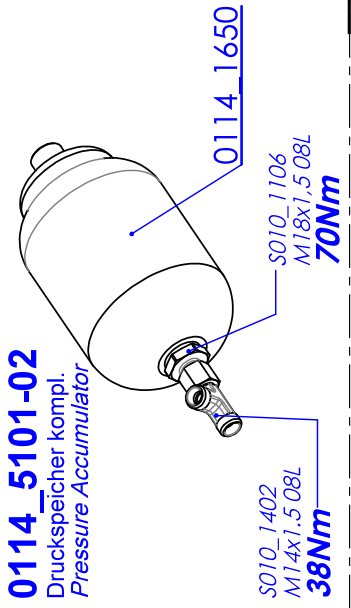

**0115\_0218**  
Hydraulik Tank  
Hydraulic Tank Unit

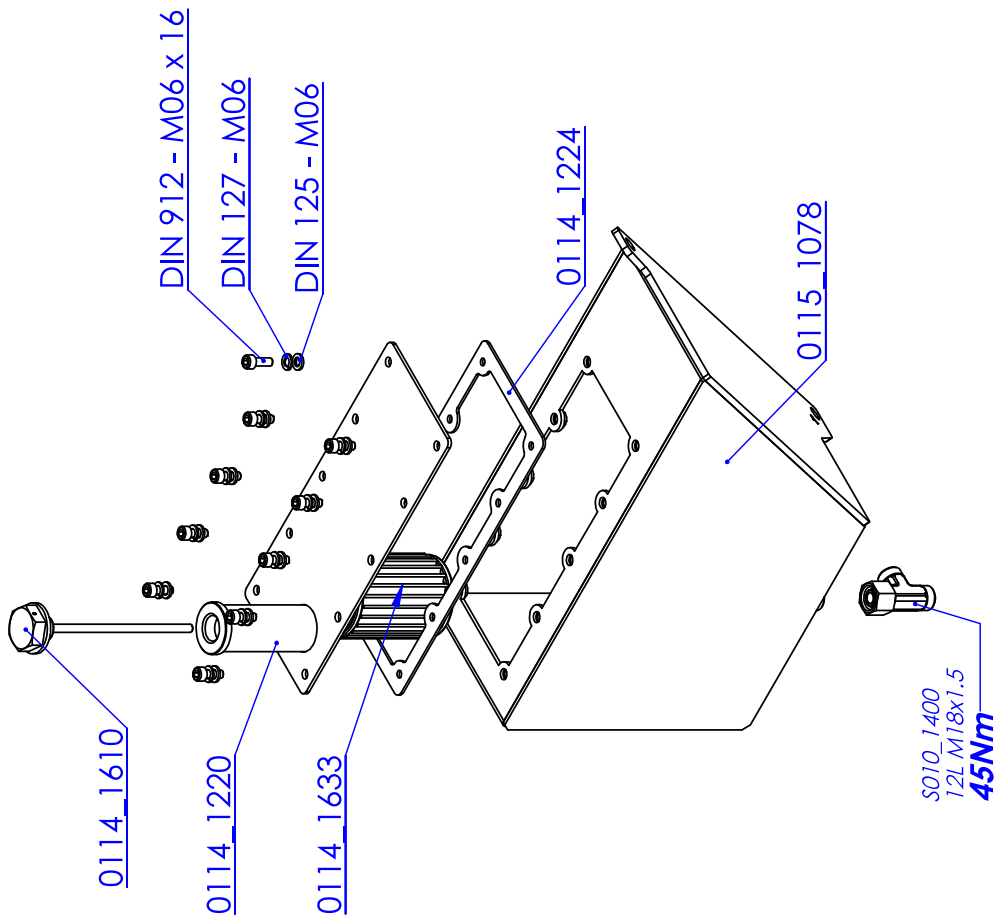

## 0114\_1234-11

Hydraulikeinheit-63/RS-Ventil  
Hydraulic Unit-63/RS-Valve

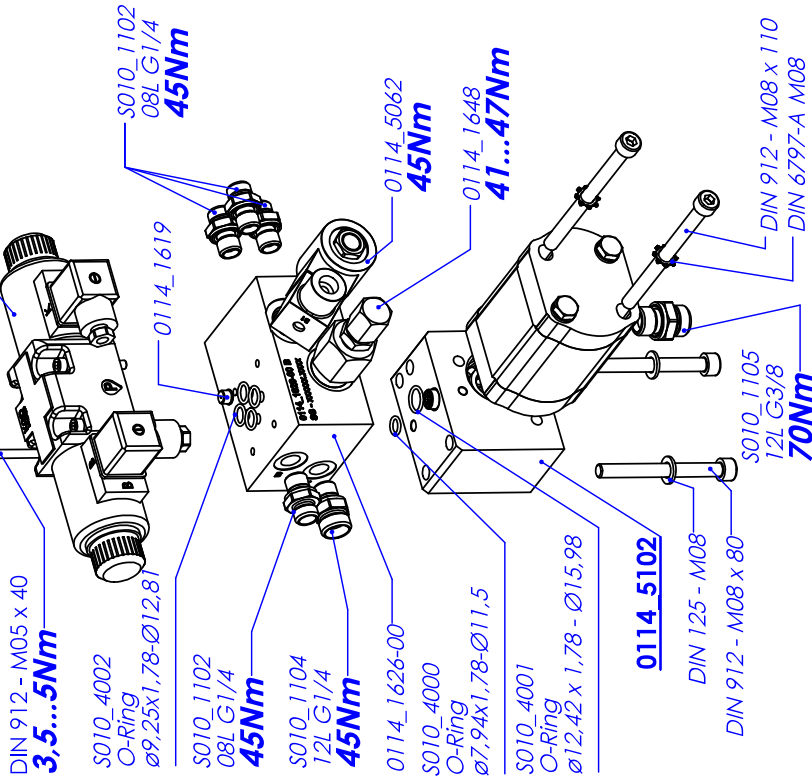

## 0114\_5102

Vorsatzlager-Druckmotor  
Hydraulic motor front bearing

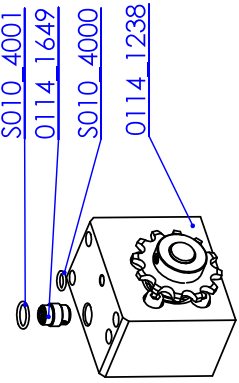

## 0114\_1786

Hydraulik Kettenspanner  
Hydraulic Chain Tensioner

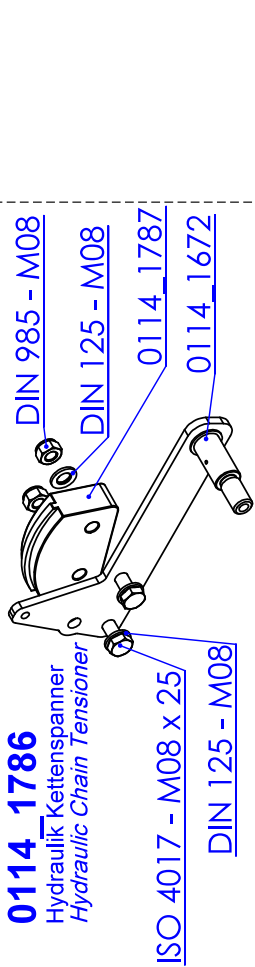

## 0114\_1229-11

Hydraulikeinheit-63/RS-Ventil  
Hydraulic Unit-63/RS-Ventil

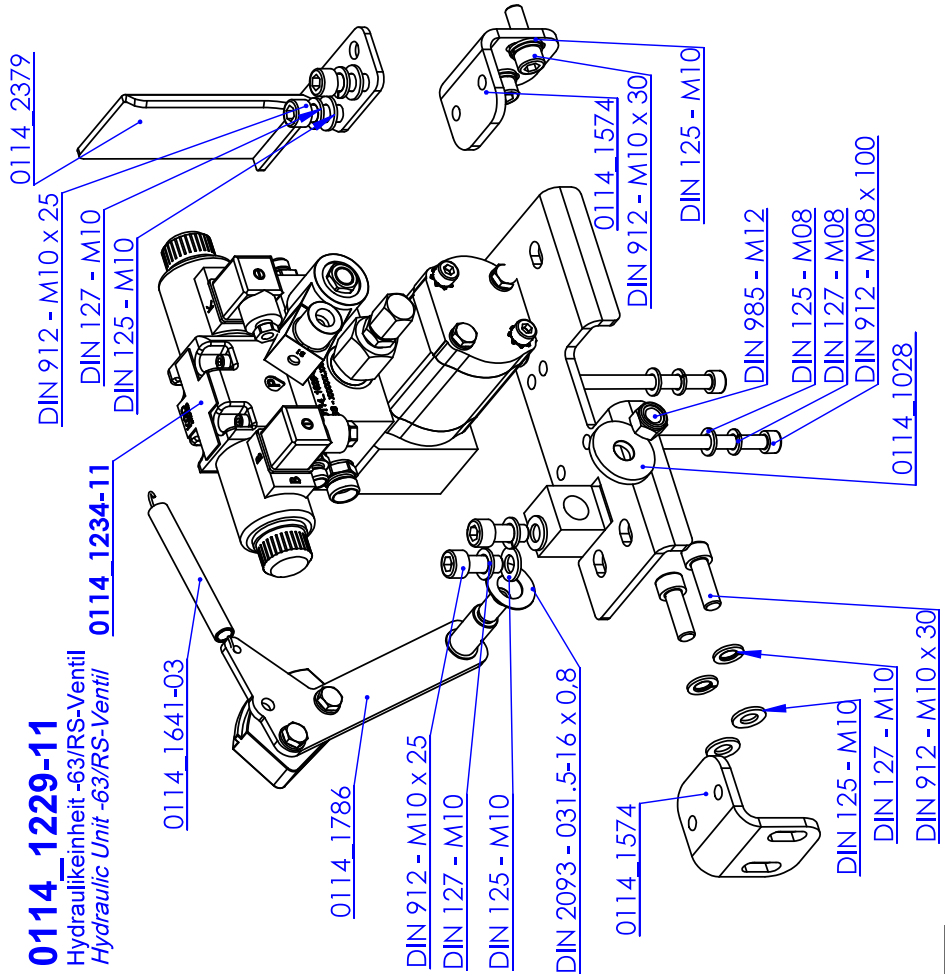

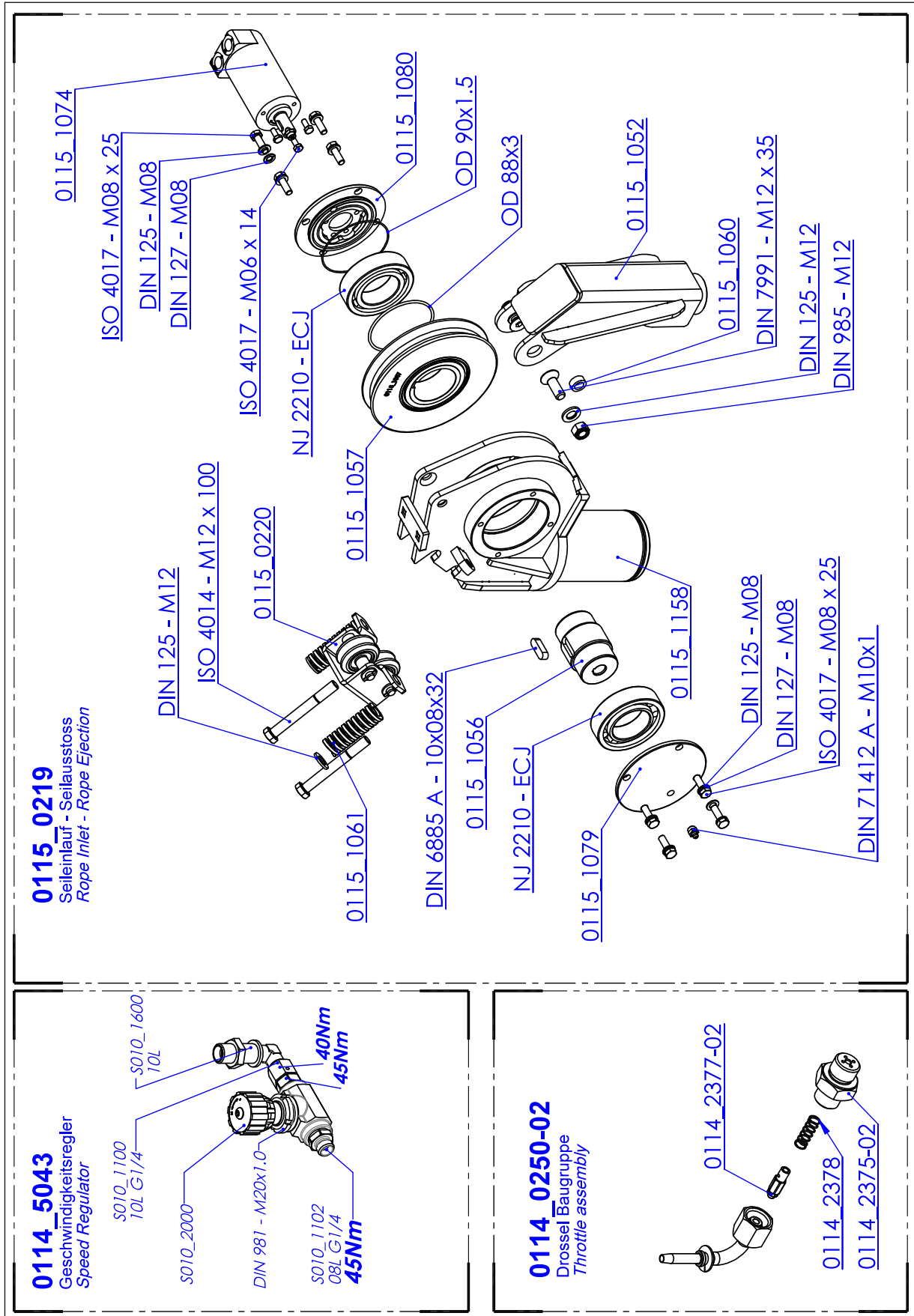

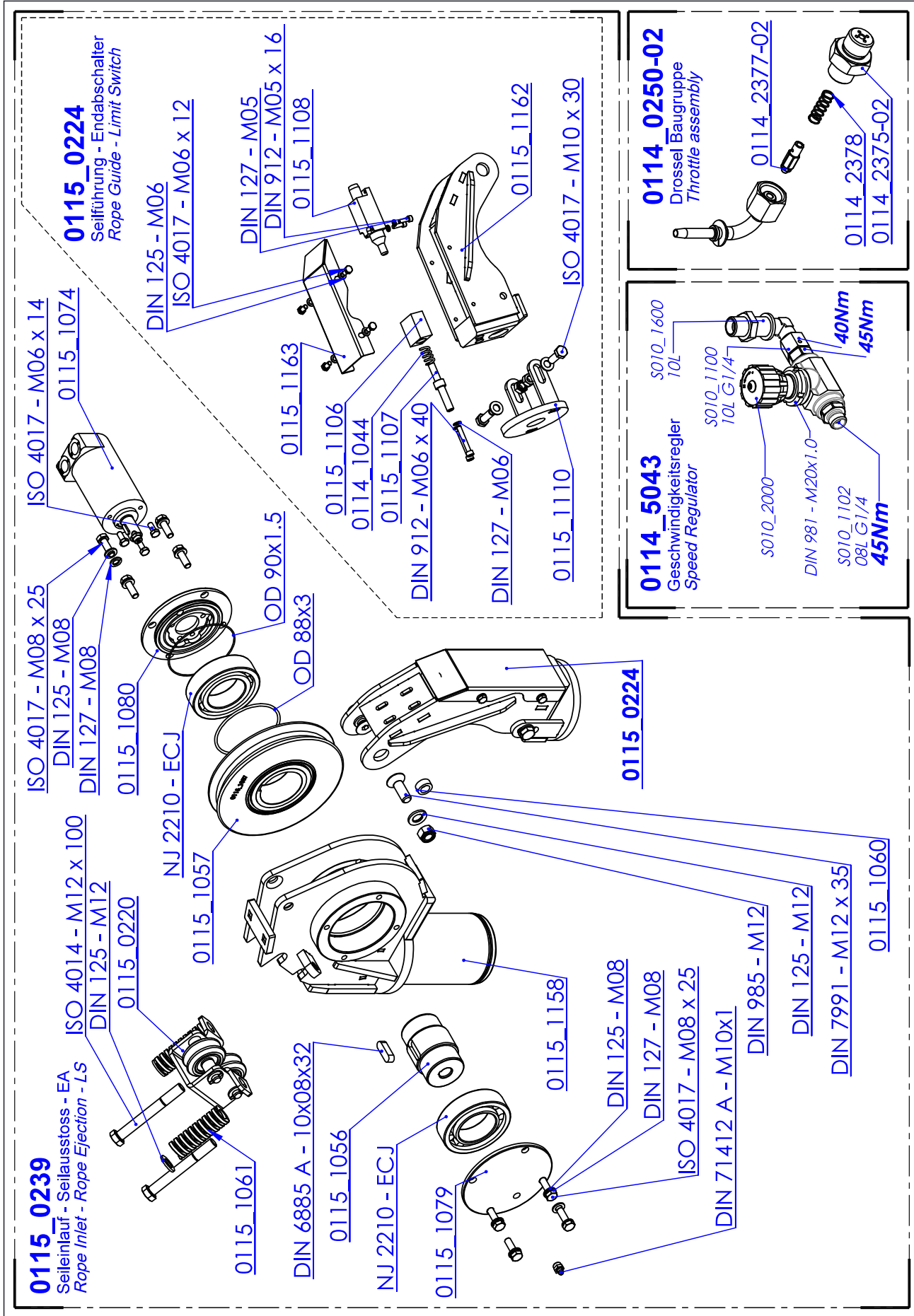



## 11. Warranty sheet

We guarantee:

- that the product will operate fault free, if operated according to enclosed operating instructions;
- that we will repair any fault or defectiveness within 45 days during the warranty period. In case the product is not repaired within the mentioned term, we will replace it with a new product on customer's request.

The product is warranted 36 **MONTHS** from the day of purchase, which must be proved by the customer with the certified warranty sheet (stamp of the shop, date of purchase and salesman's signature, serial number and year of manufacture). Warranty sheet is valid only if shown together with original invoice! The warranty covers any parts and labor against defects in material and workmanship. In case of repairs performed by unqualified person, or when using non-original spare parts, the customer loses all claims of warranty!

Our warranty is void also in case of:

- Damages caused by not following these operating instructions;
- Damages which are customer's fault;
- Damages resulting from improper use or overload and operation in unsuitable conditions.

## Garantieantrag / Warranty form

KGD internal No.: \_\_\_\_\_

owner  
winch

First- and last name: \_\_\_\_\_

Street, No.: \_\_\_\_\_

Postal code, city: \_\_\_\_\_

Phone-No.: \_\_\_\_\_

Serial-No.: \_\_\_\_\_

winch

Type: \_\_\_\_\_

Purchase date: \_\_\_\_\_

Purchased at (dealer): \_\_\_\_\_

Problem description, changed parts, suggestions:

---

---

---



# KÖNIGSWIESER

Die Seilwinde. Ein Leben lang!

The specialist for forestry winches

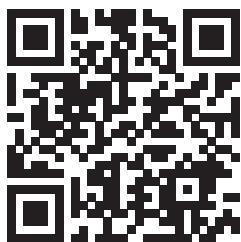

Königswieser Gerätetechnik GmbH  
Einsiedlinger Str. 51, 4655 Vorchdorf  
Tel. +43 (0) 7614 / 22122  
office@koenigswieser.com  
www.koenigswieser.com

Status October 2023

