

KÖNIGSWIESER

Die Seilwinde. Ein Leben lang!



Operating manual

KGD 40 M

0113_0021



KÖNIGSWIESER

Die Seilwinde. Ein Leben lang!

Table of contents

1. Technical specification	4
2. Declaration of Conformity	5
3. Introduction	6
4. Safety Instructions	7
5. Mounting	8
Mounting to the 3-point hitch	8
Assembly of the pto shaft	8
PTO is optional equipment	8
Shorten the drive shaft	8
6. Operation Instructions	9
Wire rope unwinding	9
Pulling	10
Release the wire rope under-load	10
7. Settings	11
Installing a new rope	11
Coiling the wire rope tightly onto the drum	12
Setting the wire release power	12
Setting the winch brake power	13
8. Maintenance	14
Checking and tightening the drive chain	14
Lubrication	15
9. Removal of Faults	16
10. Spare parts catalogue	18
11. Warranty sheet	25
12. Notes	26

1. Technical specification

KGD 40 M

Pulling force below	4,0 to
Pulling force above	2,25 to
Wire rope medium speed	0,9 m/s

Wire rope maximum length

Ø 8,5 mm	100 m
Ø 9 mm	90 m
Ø 10 mm	70 m

Weight (without wire rope)	249 kg
Width	1'300 mm
Height with protective net	2'000 mm
Category of 3-point Mounting	I + II
Tractor required power	from 15 kW

2. Declaration of Conformity

in accordance with Directive 2006/42/EC

We, the

Königswieser Gerätetechnik GmbH
A - 4655 Vorchdorf
Einsiedlingerstr. 51

declare under our sole responsibility that the product:

Logging winches

KGD 35 M, KGD 40 M, KGD 42 M, KGD 45 M, KGD 55 M, KGD 65 M

to which this declaration refers, complies with the relevant essential health and safety requirements of Directive 2006/42/EC and the requirements of the relevant EC Directives.

The following standard(s) and / or technical specification(s) were used for the appropriate implementation of the safety and health requirements specified in the EC directives:

EN ISO 19472:2006

Vorchdorf, 08.05.2024

Königswieser Günter, CEO

3. Introduction

This manual describes the KGD winch and includes information and maintenance instructions for a safe and efficient machine operation.

Please, read the operation and service manual carefully even if you are an experienced winch user. The manuals include information required for an efficient and safe operation of the machine. Regular maintenance guarantees economical and correct machine operation.

The skidding winch is delivered test run and test loaded.

4. Safety Instructions

Do not use the winch, before you have read and understood the manual! The owner is responsible for the guidance of all persons, who have to deal with the device. Do not use or service the winch before the becoming acquainted with it.

1. Only skilled persons may use and service the winch.
2. The winch must always be checked before use and at least once a day the safety conditions and the possible faults must be checked.
3. Check the moving parts. They have to be fastened to their places and in good condition. All the protections and the limiters have to be in places.
4. The winch must not be used even partly, without the protection parts.
5. When winching to downhill, the winch must be pulled from the side through an extra snatchblock.
6. It is perilous to be in the area between a load connected to the cable and a winch.
7. Before using the winch get acquainted with the controllers of the winch, test the stopping functions of the winch and of the tractor and all the other functions. Each function has to be in perfect order.
8. Check that the winch is free of rubbish and other obstructions.
9. Check that all the outsiders are in a safe area, at a distance of at least 15 metres, from the running machine. Warning signs must be installed in the area of approaching roads .
10. The cable must not be touched during winching with the hands.
11. When the winch is used on slopes, the load must not be followed from below.
12. The maximum load must be adapted to respective conditions.
13. Check that the moving chains are carefully fastened. The cable must not be coupled directly to the load.
14. The safety factor must be 2.5 for cable type couplings and 2 for chain type couplings.
15. Inform all skidding winch users about the dangers and how they can be avoided.
16. The skidding winch may be operated only if it is attached to a tractor.
17. The winch has to be fastened to 3--point hitch of the tractor. Defective fastening may cause a dangerous situation.
18. Do not let children or incapable persons operate the winch.

5. Mounting

Mounting to the 3-point hitch

The winch can be mounted to the 3-point linkage of any tractor. Power transmission is obtained through universal shaft from tractor.

Assembly of the pto shaft

If the PTO shaft is too long it may get pressed when the three point hitch is lifted up. This may cause damage to the bearings of the winch or to the PTO of the tractor. The PTO shaft must not be too short in any position. The PTO length is suitable, if the pipes do not reach the bottom.

PTO is optional equipment

1. Mount the winch to the 3-point hitch of the tractor.
2. Raise the winch high enough to get the PTO shaft of the tractor and the winch to a horizontal level.
3. If you have a shortened PTO shaft available, put one end into the drive shaft and check that the distance of the locking of the other end. Take into account the additional clearance of approx. 20 mm.
4. Fasten the other end of the PTO shaft in its place and also move the winch sideways at the same time securing that the axis does not base.

Shorten the dirve shaft

Both PTO halves must be shortened by equal amounts.

- First cut the thicker cover to a correct lenght. Remember 20 mm cleanrance. Then cut away the same amount from the form pipe. Make a similar shortening to the second half of the PTO shaft. Remove the burr with the file.
- Connect the PTO shafts within each other. Make sure by moving eevator carefully up and down that the shortening of the axis is sufficient. Check that the axis have 20 mm latitude.

6. Operation Instructions

Wire rope unwinding

When the winch is properly connected, we can begin with unwinding of the wire rope.

When unwinding, we have to be careful not to unwind the wire rope completely or leave at least three winds on the drum. Due to safety reasons, the wire rope is installed on the drum so that if the logs start to slide without control, the rope must “pull” itself off the drum. If the rope was pulled out with excessive force, we can pull out the entire wire rope during pulling. In this case, replace it according to the procedure, foreseen for wire rope installation.

Once the winch is correctly connected, we start to unwind the wire rope. We do this so that we pull the wooden handle on the red rope (pos. 1) and in this way move handle in direction OFF . Brake is released and the wire rope can be unwound. In case that we just installed the wire rope on the drum or we observe that it is not properly wound, we unwind the entire length of the wire rope and wind it strong, as given in the next chapter.



Warning

Steel rope must be completely unwound before first use and wind it back on the generator drum under load. For instance, we can do this so that we attach the rope to a standing tree and pull the tractor with slight braking to the tree. This procedure must be done also before trying to tow, if we towed downhill beforehand or if the rope was wound loosely during towing.

ATTENTION: Loosely wound steel rope can be damaged (stuck, bent) at greater load, so that it is prohibited to use it again.

Warranty does not apply for a steel rope, which is damaged in such manner.

Pulling

Lower the winch on the ground. In this manner, the winch strengthens on the surface by the board and we engage parking brake. Under no circumstances it is allowed to start towing, before the winch is secure on the ground.

Before starting pulling the blue rope, check that it is properly wound between the small pulleys. This winding is correct when the handle returns in the starting position, after we stop pulling the rope.

If the rope is not properly wound, a situation may arise, where the winch towing does not stop on our wish, which can result in an accident.

Now start pulling on the blue cable and the winch starts to pull in the steel cable. During the interruption, the brake band automatically switches on and prevents the load from sliding when the pulling is stopped.

It is useful to know that at the constant drive power, the pulling power depends on the length of the wire rope coiled to the drum. The strongest pulling power is achieved at the first layer of coils. By multilayer coiling the pulling power decreases progressively. The pulling power changes in inverse proportion to the pulling speed, which is highest when the wire rope is fully coiled.

Release the wire rope under-load

The brake prevents tied load from sliding back, when you stop the pull. To release the stretched wire rope, quickly push and release the handle (1) repeatedly to prevent

the drum from uncoiling suddenly and loosening the coiled wire rope. If the wire rope on the drum gets loose, the outer coils of the wire rope get under the inner coils at the repeated pulling, and the wire rope gets damaged quickly.

7. Settings

Installing a new rope

- Remove cover 1
- Bring the drum in position the reach screw 2 through the opening
- Unscrew the screw
- Insert the new rope from above
- Tighten the screw and close the cover
- Coil up the wire rope onto the drum tightly (see next Chapter!)

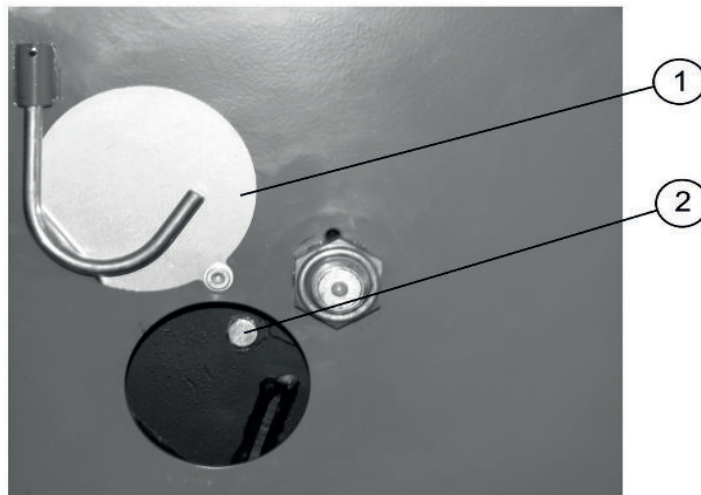

Coiling the wire rope tightly onto the drum

First, uncoil the wire rope completely and check its quality. Afterwards push the “Pull” button to coil up the wire rope onto the drum. Pay attention to coil the first five coils using minimum force and the rest of the wire rope using higher force.

You can achieve this in two ways:

- By pulling the load;
- By fastening the wire rope to a fixed object, so that the tractor is pulled towards this object.

It is recommended to do this on a slight incline, so the tractor is pulled uphill, or by braking slightly

WARNING: The wire rope must always be tightly coiled up onto the drum – before starting the work with a new winch it is necessary to uncoil the wire rope completely without any load, check its quality and tightly coil it back onto the drum: first five coils should be coiled by using minimum load and the rest of the wire rope using higher load!

Setting the wire rope release power.

Setting the wire release power

The wire rope release power must be set correctly, so the drum stops immediately after releasing the wire rope. This prevents the wire rope on the drum from releasing by itself. Set the wire rope release power using the wing nut. By screwing or unscrewing the wing nut, the wire rope release power increases or decreases.

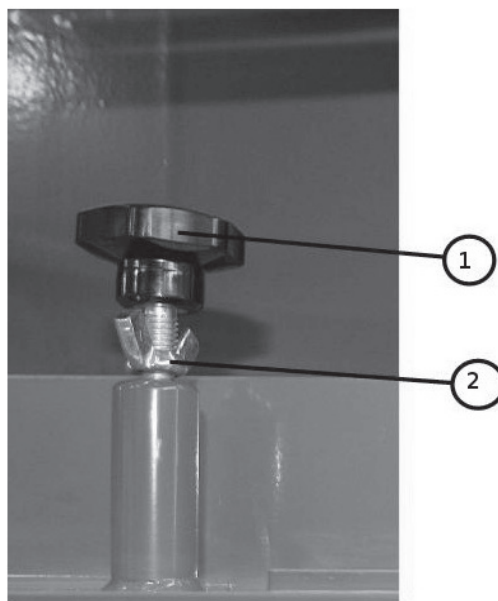

Setting the winch brake power

At the end of pulling, the differential brake automatically engages. The brake is factory set, and a new setting is usually not required in the warranty period. After a longer period partial wear of the frictional padding on the brake belt occurs and it is required to set it again. This is required when the brake does not hold the burden as described in the beginning of this paragraph. Perform the setting by tightening the nuts (pos.1+2), which tightens the spring. Then, control the distance between the nut (pos. 2) and cylinder on a lever (pos. 3). This distance should be 5 mm, when the brake is not loaded. If the brake is properly set, is determined when unwinding the wire rope from the drum, which must unwind easily. This unwinding depends on previously set pre-brake, which is described in the previous chapter.

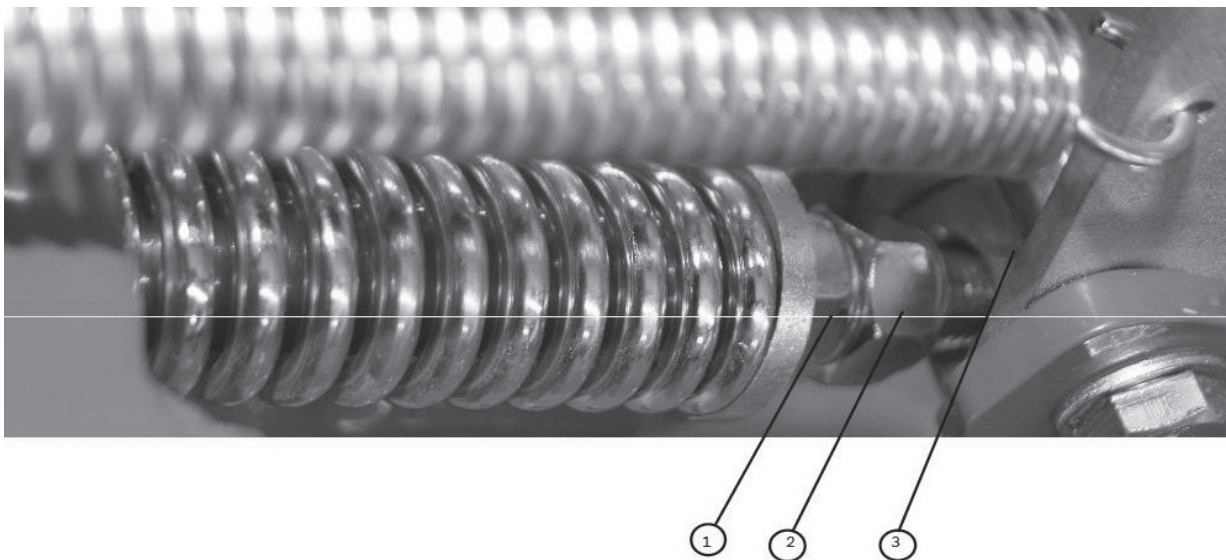

8. Maintenance

Checking and tightening the drive chain

- Open screws (4) from the back side. Try not to open too much so the nuts dont fall off.
- Tighten nut (6) until chain (3) is tight.
- Tighten screws (4)
- Check chain – you should be able to move it 4-6mm
- now open screws (2)
- Tighten nut (1) until chain (5) is tight
- Tighten screws(2)
- check chain – you should be able to move it 4-6mm

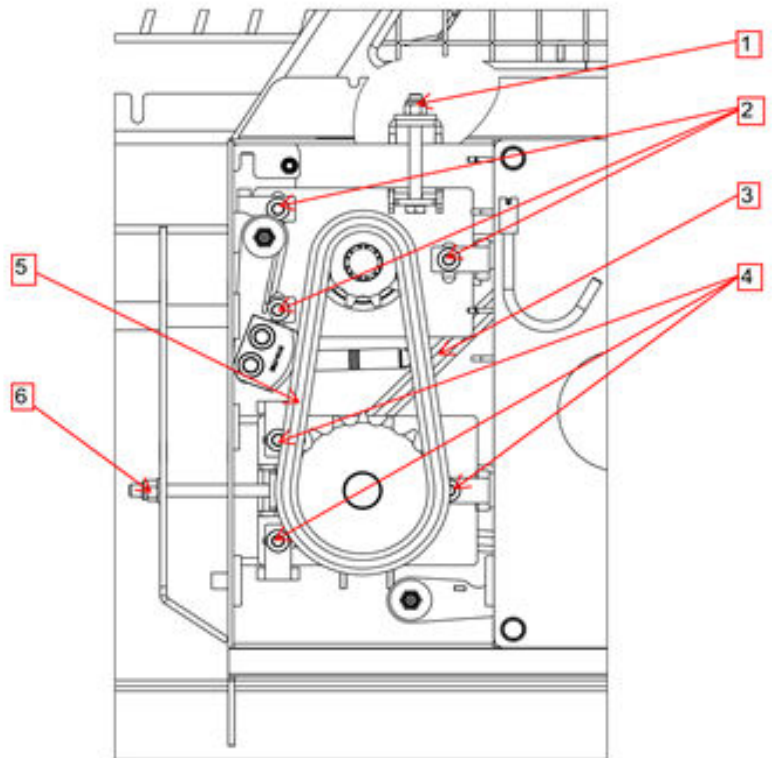

Lubrication

Before proceeding with maintenance work, shut down the engine, remove the key and wait for all moving parts to stop.

There is a grease fitting on the winch, which enables greasing of the upper pulley and guide. The second grease fitting is on the housing of the lower pulley. Greasing is required every 60 hours of operation. The PTO shaft needs to be lubricated according to instructions of the manufacturer.

Non-frequent greasing can cause wear of slide elements and consequentially a defect, which is not subject to warranty terms!

Drive chain must be lubricated every 200 hours of operation. Lubricate it with spray for lubrication of chains or special grease, which does not melt at high temperatures, because the grease can come into contact with friction coating of the clutch.

First, remove the PTO shaft protection. Clean the chain before lubrication. Do not lubricate the part, where the grease can reach clutch with application.

If grease comes into contact with friction coating of the clutch due do improper and excessive lubrication, this would mean a drastic reduction in pulling force and consequentially it would be required to replace the blades of the clutch, which cannot be a subject of this warranty!

All other bearings on the winch are of closed type, therefore greasing is not necessary.

9. Removal of Faults

Determined faults (malfunctions)	Cause	Procedure for removal of faults (trouble)
Insufficient pulling force	Grease on frictional padding of the clutch	Replace clutches
	Burnt frictional padding of the clutch	Clean padding with sandpaper or grind (thickness approximately 0.5 mm)
	Improper setting	Setting according to instructions
	Worn frictional padding of the clutch	Replace clutches
	Incorrectly installed clutch	Install according to technical documentation
Insufficient brake force	Improper setting	Setting according to instructions for use
	Grease in the padding of the brake belt	Replace the brake belt
	Damaged brake belt	Replace the brake belt
	Damaged brake mechanism	Replace damaged parts
	Other	Contact service company
Wire rope cannot be pulled out or the pulling is difficult	Improper setting of prebrake	Setting according to instructions
	Improper setting of brake	Setting according to instructions
	Damaged or stuck wire rope	Pull out the rope with a tractor and, if required, install a new wire rope
	Damaged brake belt	Replace the brake belt
	Brake handle is not in correct position	Proceed according to instructions for use
	Damaged or corroded engagement mechanism	Grease the engagement mechanism with WD spray or, if required, replace the engagement mechanism
	Other	Contact service company

Determined faults (malfunctions)	Cause	Procedure for removal of faults (trouble)
The winch pulls, despite the clutch being disengaged	Improper setting	Setting according to instructions
	Crossed, wound rope or control of brake handle	Installed the rope in parallel manner
	Lever, connecting the brake handle, does not allow return in disengaged position	Check the lever
	Damaged engagement mechanism.	Repair or replace the engagement mechanism.
	Damaged winch drum	Replacement or repair of the drum
	Not enough clutch distance	Setting according to instructions
	Broke part of frictional padding on the clutch	Replace clutches
	Excessively tensioned drive chain.	Chain setting according to instructions
The winch makes noise with operation	Insufficiently tensioned drive chain	Tension the chain, as described in the instructions
	Damaged or worn bearings	Replace bearings

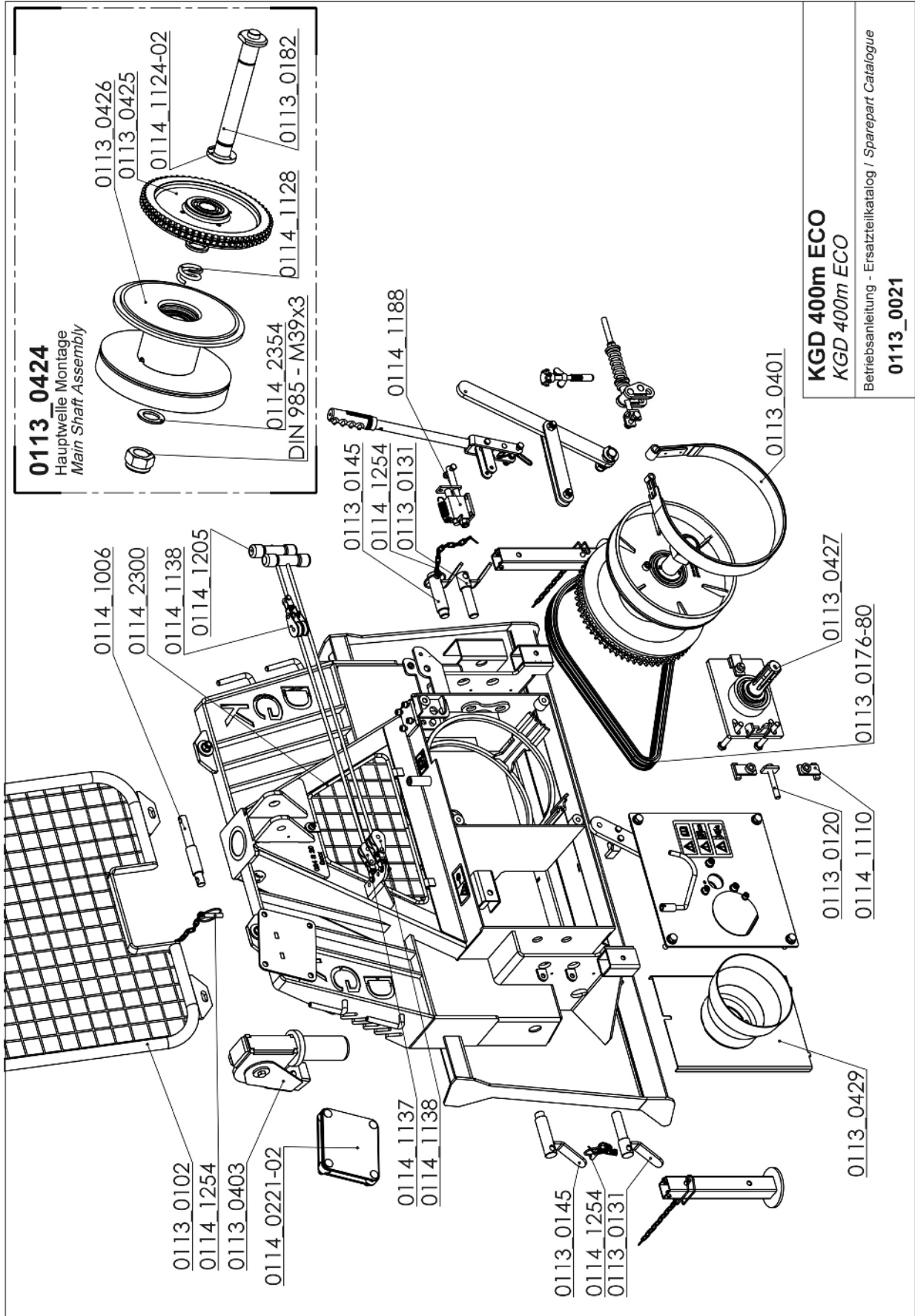

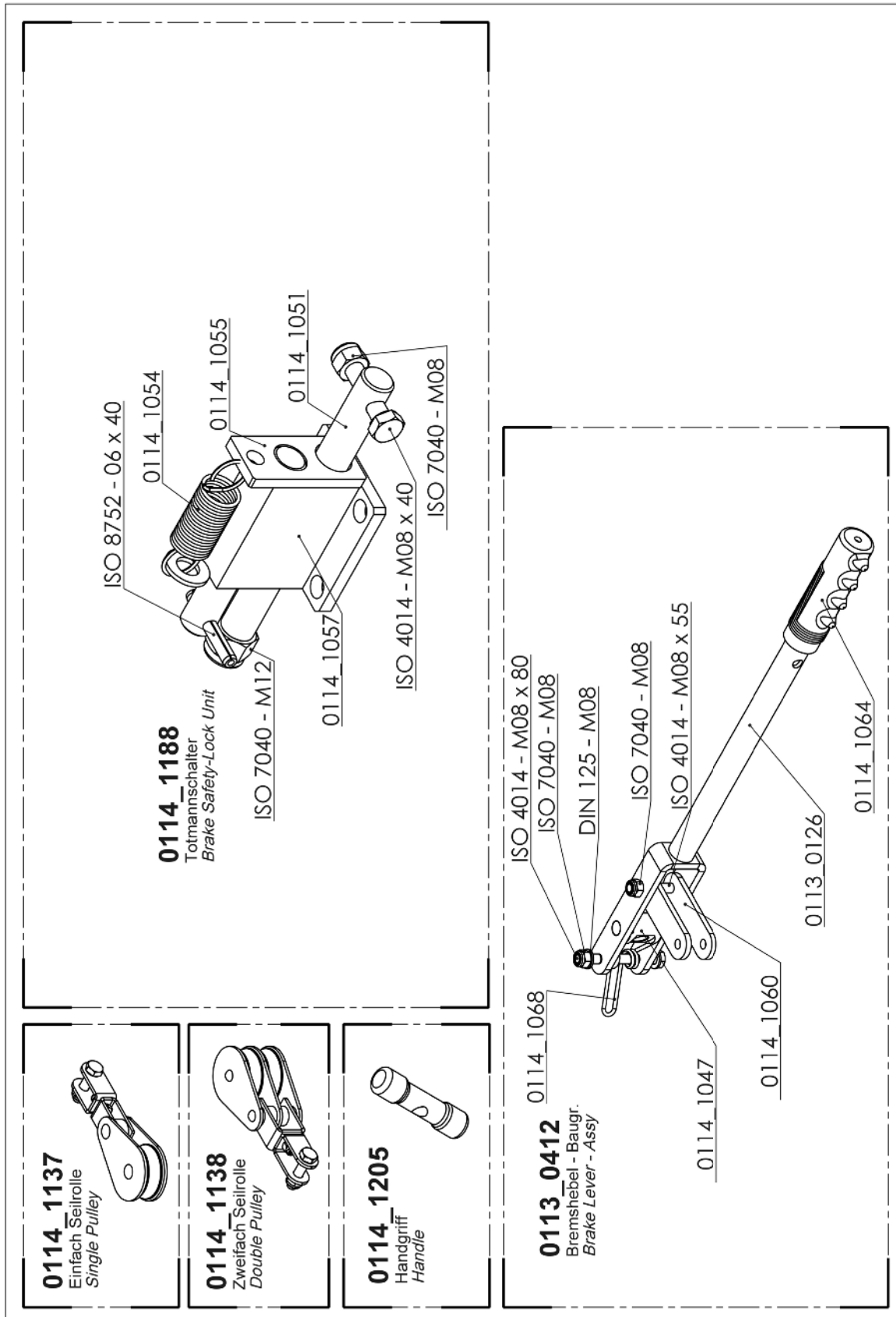

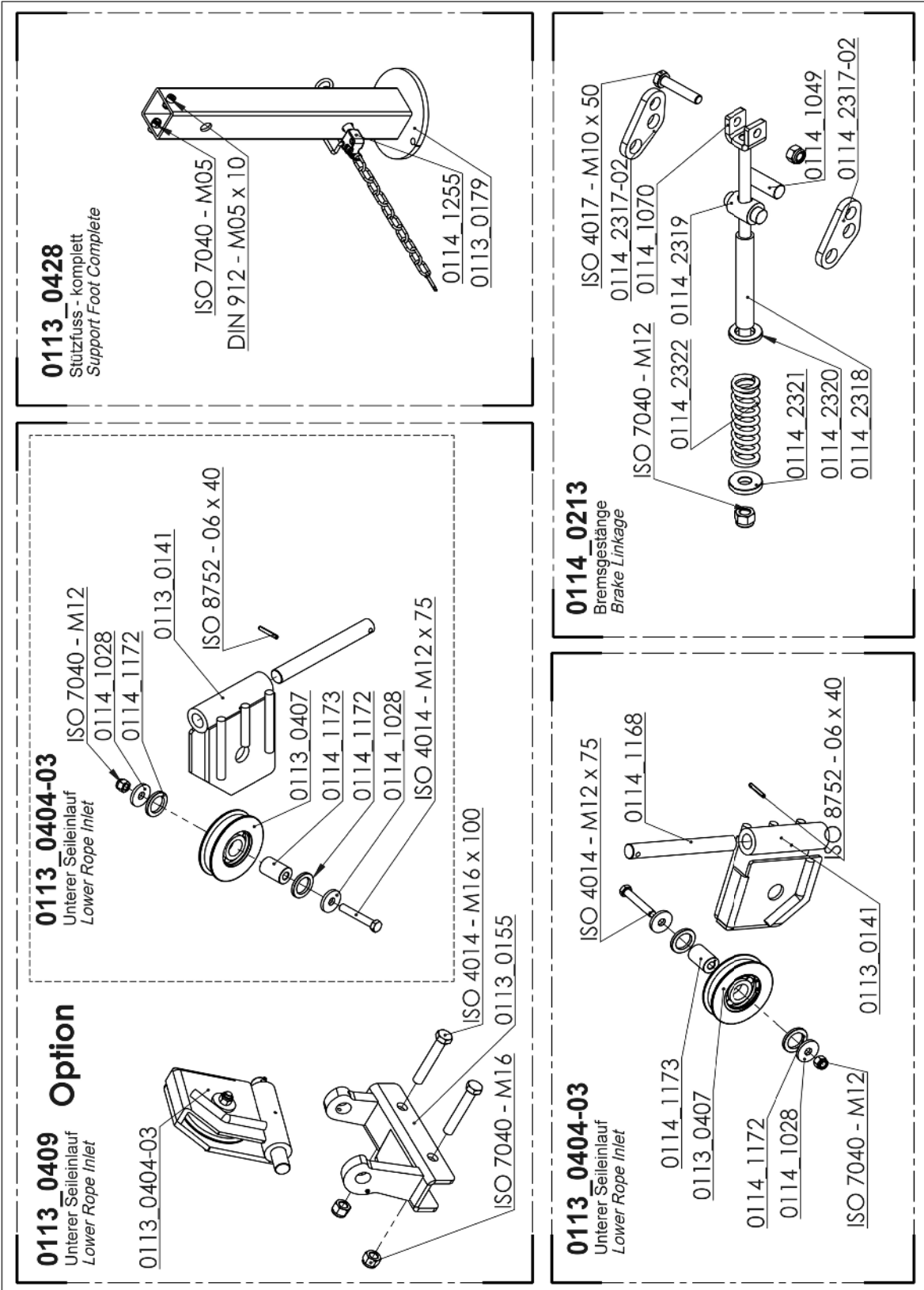

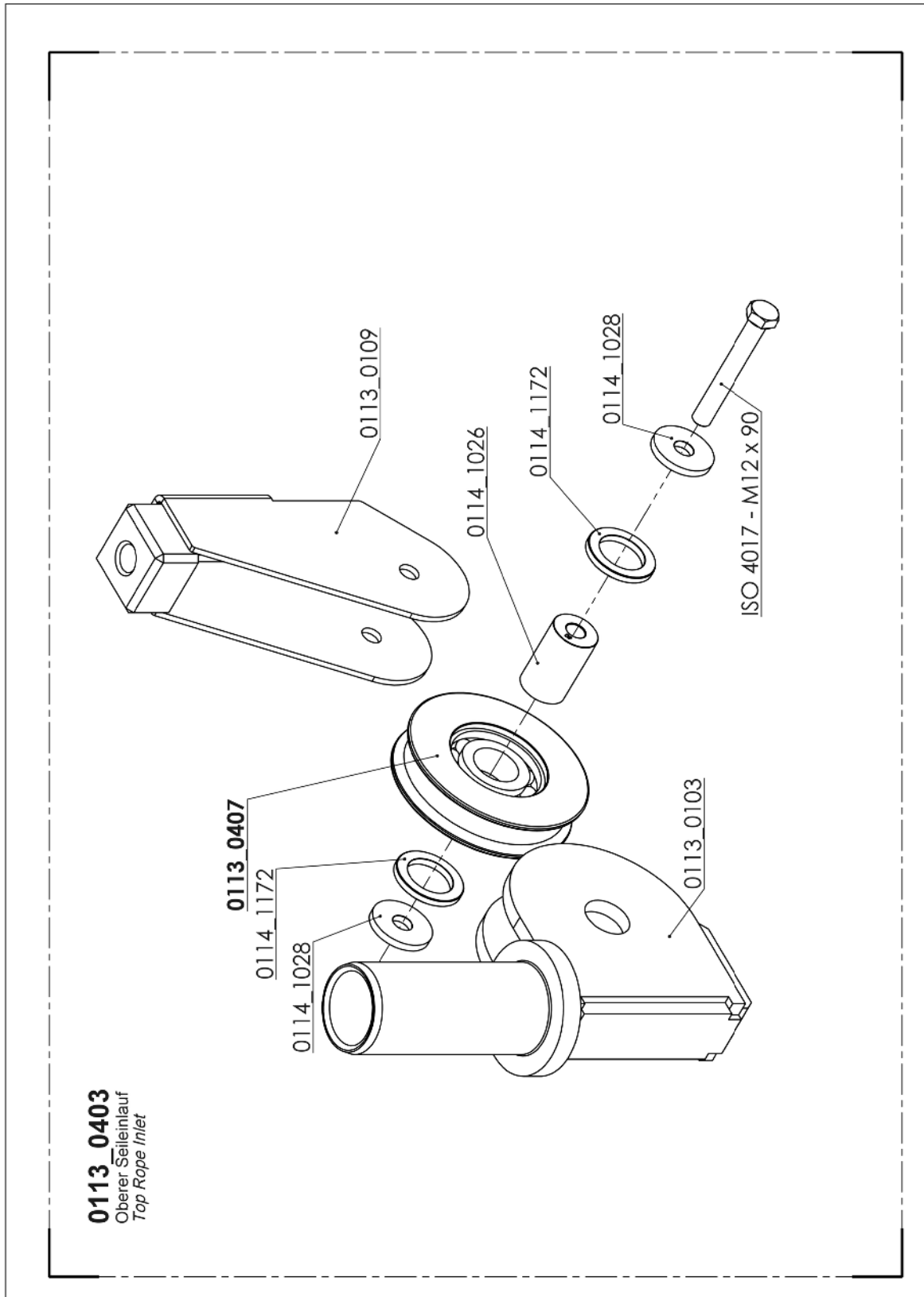

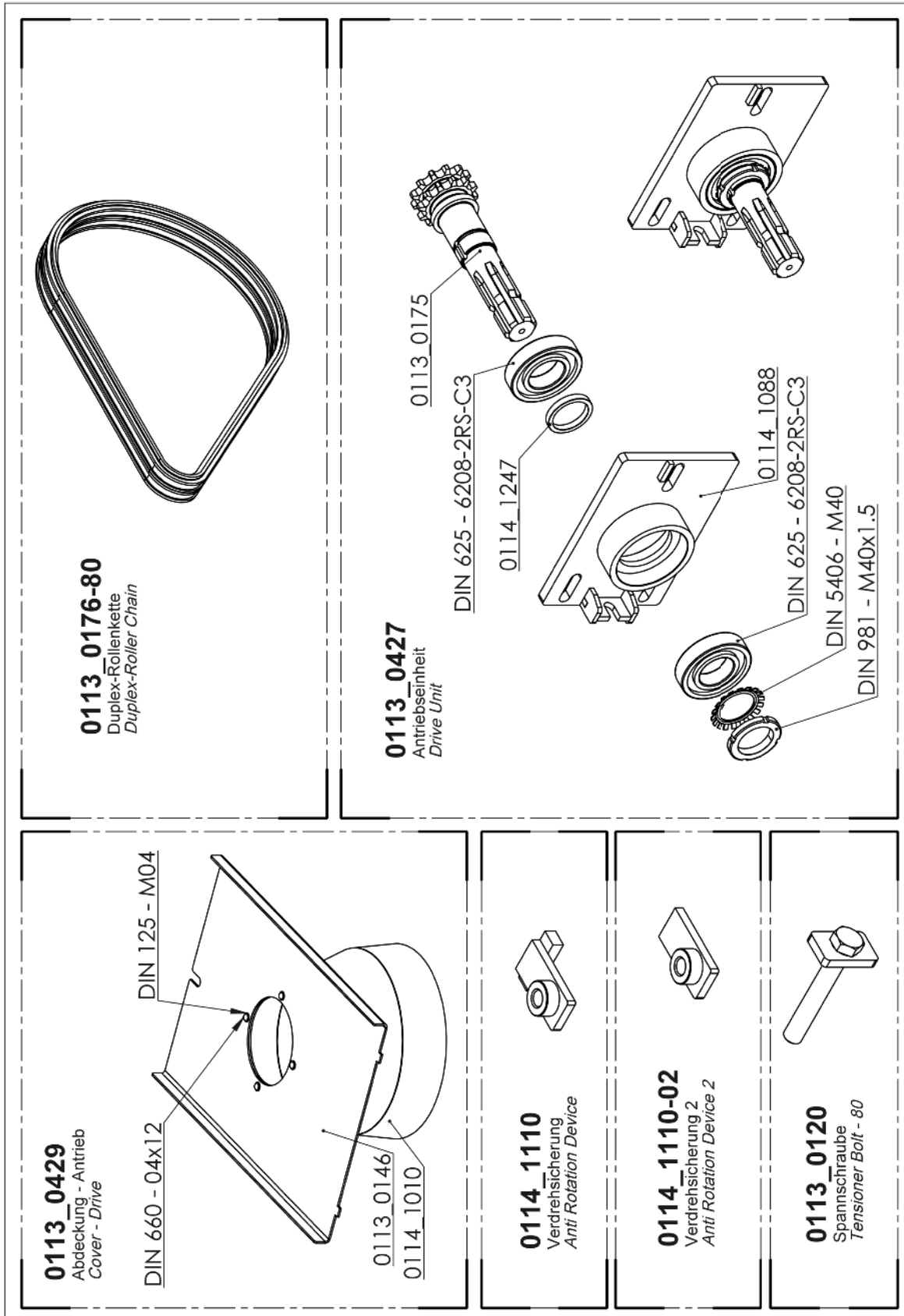

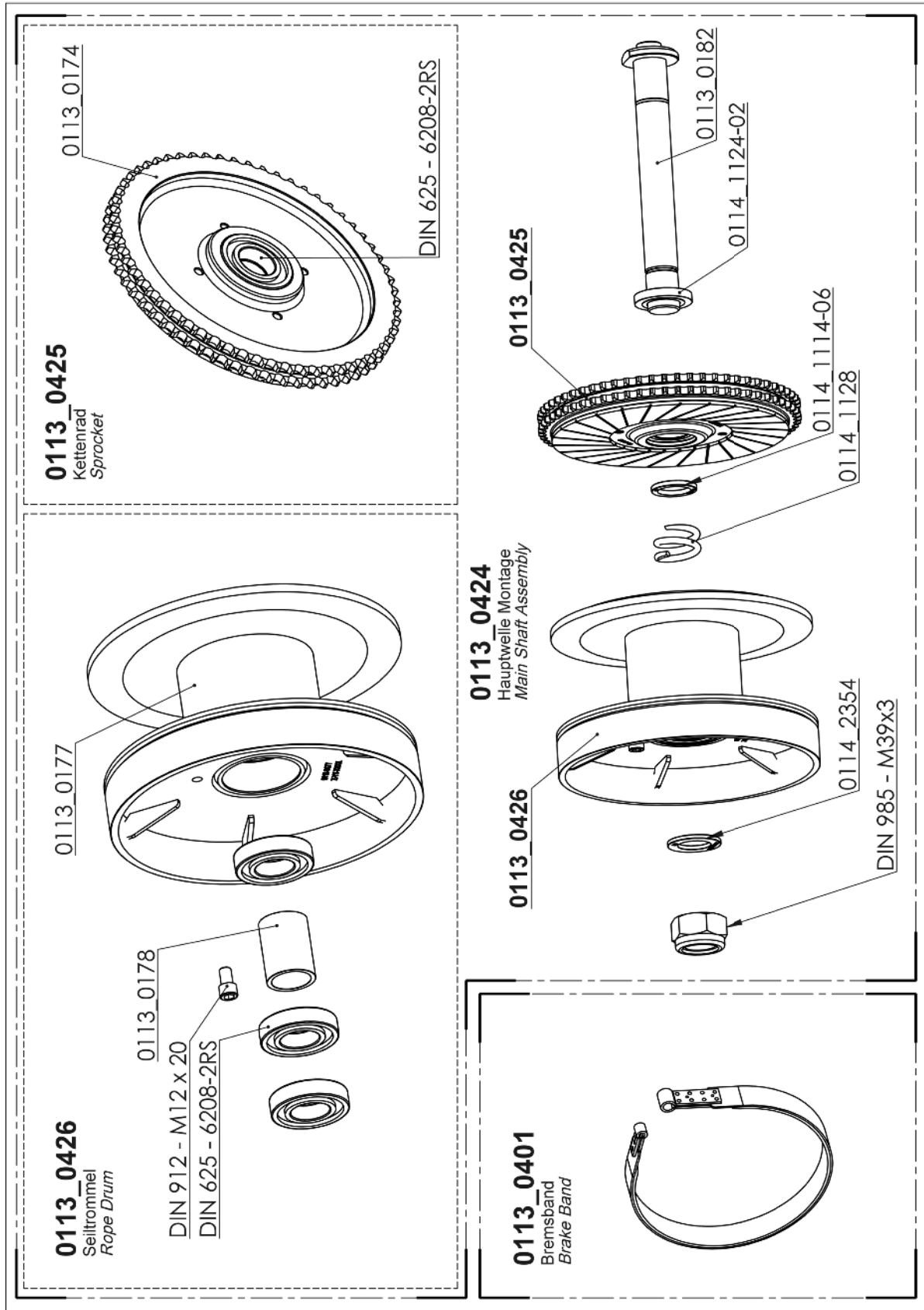

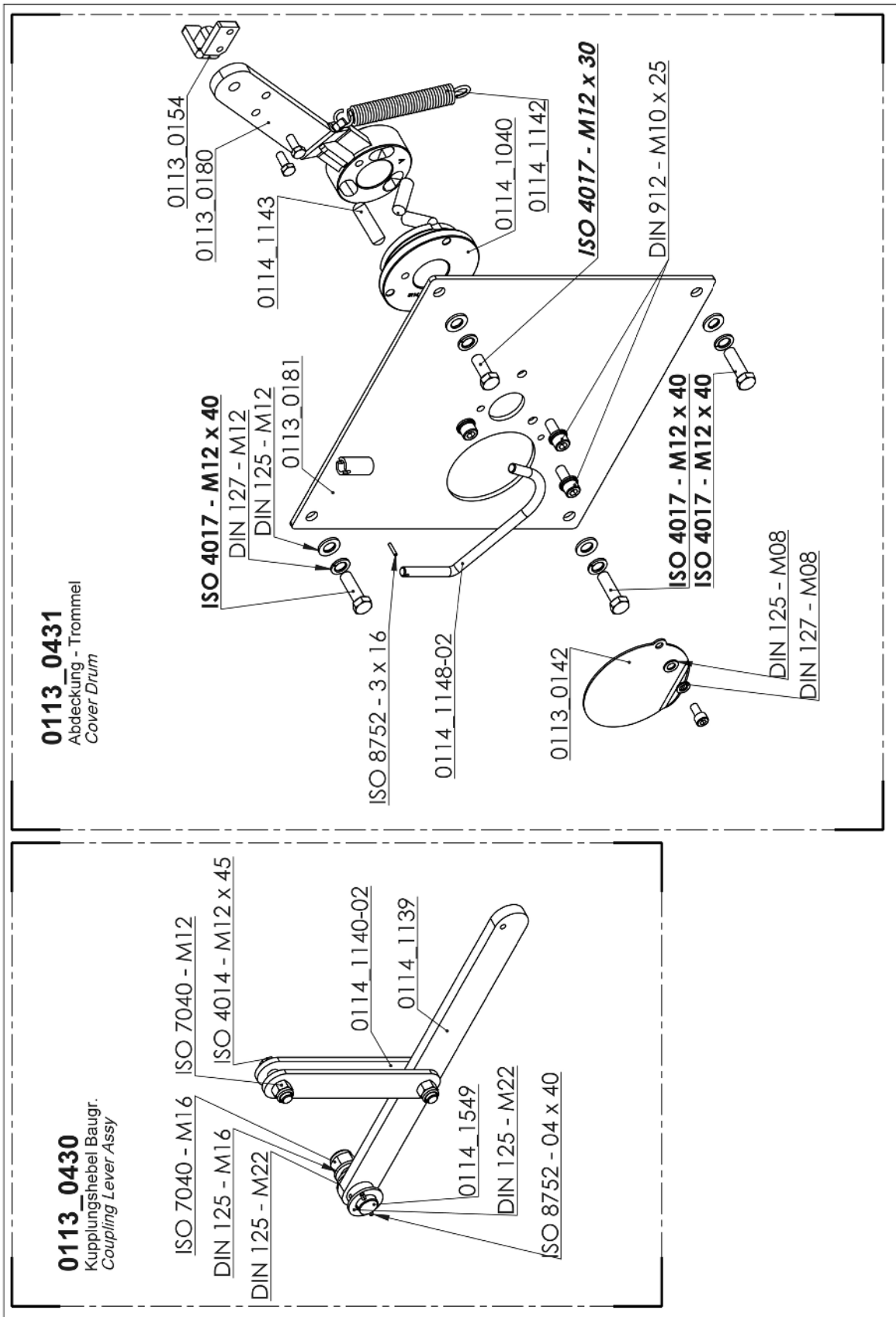

11. Warranty sheet

We guarantee:

- that the product will operate fault free, if operated according to enclosed operating instructions;
- that we will repair any fault or defectiveness within 45 days during the warranty period. In case the product is not repaired within the mentioned term, we will replace it with a new product on customer's request.

The product is warranted 36 **MONTHS** from the day of purchase, which must be proved by the customer with the certified warranty sheet (stamp of the shop, date of purchase and salesman's signature, serial number and year of manufacture). Warranty sheet is valid only if shown together with original invoice! The warranty covers any parts and labor against defects in material and workmanship. In case of repairs performed by unqualified person, or when using non-original spare parts, the customer loses all claims of warranty!

Our warranty is void also in case of:

- Damages caused by not following these operating instructions;
- Damages which are customer's fault;
- Damages resulting from improper use or overload and operation in unsuitable conditions.

Garantieantrag / Warranty form

KGD internal No.: _____

First- and last name: _____

Street, No.: _____

Postal code, city: _____

Phone-No.: _____

Serial-No.: _____

Type: _____

Purchase date: _____

Purchased at (dealer): _____

Problem description, changed parts, suggestions:

KÖNIGSWIESER

Die Seilwinde. Ein Leben lang!

The specialist for forestry winches

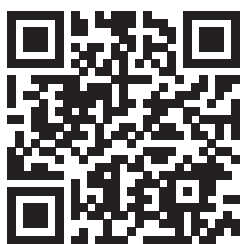

Königswieser Gerätetechnik GmbH
Einsiedlinger Str. 51, 4655 Vorchdorf
Tel. +43 (0) 7614 / 22122
office@koenigswieser.com
www.koenigswieser.com

Status January 2024

